

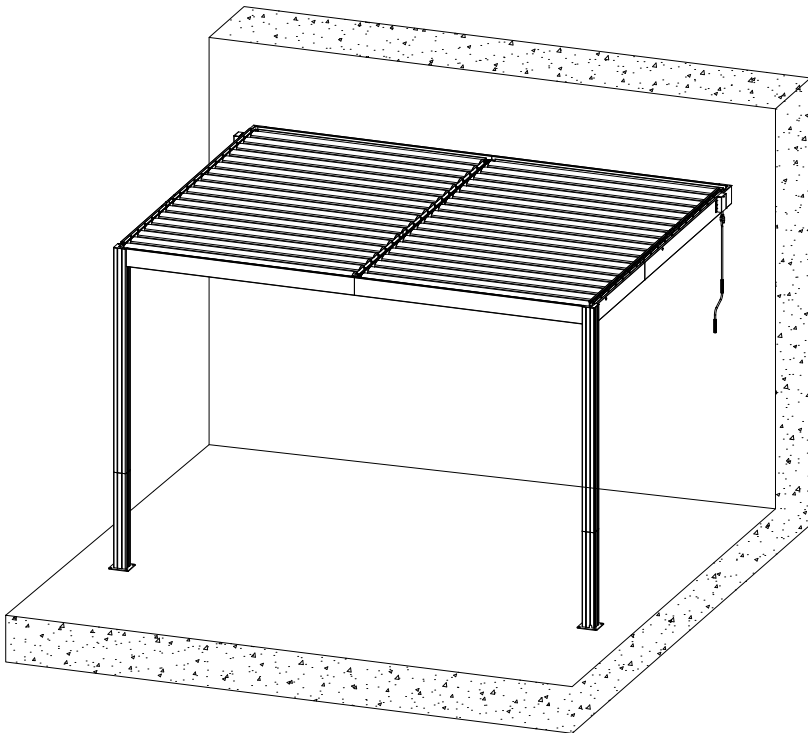

Manual

Louvered Outdoor Pergola G21

Trenton Premium, 4x4 m



EN DE CZ SK HU PL HR SLO

۲۱



Thank you for purchasing our product.

Before using this unit, please read this manual.

Assembly instructions:

Prior to the assembly please read all instructions and information carefully. Check whether you have all parts which are necessary for the assembly.

Please mind your own safety.

1. Use protective clothing and gloves as some parts might be sharp.
2. During the assembly no children or pets should be present in the working area.

Care and maintenance:

Clean with a rag and water.

The English version of the manual is an exact translation of the original manufacturer's instructions. Images used in this manual are for illustrational purposes only and may differ from the actual product.



Vielen Dank für den Kauf unseres Produktes.

Bevor Sie dieses Gerät verwenden, lesen Sie diese Anleitung.

Montageanleitung:

Vor der Montage lesen Sie bitte alle Anweisungen und Angaben vorsichtig. Überprüfen Sie, ob alle Teile, die für die Montage notwendig sind, vorhanden sind.

Bitte beachten Sie zu Ihrer eigenen Sicherheit.

1. Tragen Sie Schutzkleidung und Arbeitshandschuhe, da einige Teile scharfe Kanten haben können.
2. Während des Zusammenbaus sollten sich keine Kinder oder Tiere im Arbeitsbereich aufhalten.

Pflege und Wartung:

Mit einem Lappen und Wasser reinigen.

Die deutsche Version der Anleitung ist eine genaue Übersetzung der Anleitung des Herstellers. Die in diesem Handbuch verwendeten Bilder dienen nur zur Illustration und können nicht genau das Produkt entsprechen.

GZ

Děkujeme za nákup našeho výrobku.

Před použitím si prosím přečtete tento návod.

Montážní návod:

Dříve, než začnete s montáží, pečlivě si prostudujte všechny pokyny a informace. Zkontrolujte, zda máte všechny potřebné díly pro stavbu.

Dbejte na svoji bezpečnost.

1. Při montáži použijte ochranný oděv a rukavice, protože některé části mohou být ostré.
2. V době montáže by se po staveništi neměly pohybovat děti a domácí zvířata.

Péče a údržba:

Čistěte za pomoci hadru a vody.

Česká verze návodu je přesným překladem originálního návodu výrobce.

Fotografie použité v manuálu jsou pouze ilustrační a nemusí se přesně shodovat s výrobkem.

SK

Ďakujeme za nákup nášho výrobku.

Pred použitím si prosím prečítajte tento návod.

Montážny návod:

Skôr, než začnete s montážou, pozorne si preštudujte všetky pokyny a informácie. Skontrolujte, či máte všetky potrebné diely na stavbu.

Dbajte na svoju bezpečnosť.

1. Pri montáži používajte ochranný odev a rukavice, pretože niektoré časti môžu byť ostré.
2. V čase montáže by sa po stavenisku nemali pohybovať deti a domáce zvieratá.

Starostlivosť a údržba:

Čistíte za pomocou handry a vody.

Slovenská verzia návodu je presným prekladom originálneho návodu výrobcu.

Fotografie použité v návode sú len ilustračné a nemusia sa presne zhodovať s výrobkom.



Köszönjük, hogy megvásárolta termékünket.

Kérjük, használat előtt olvassa el ezt a kézikönyvet.

Telepítési útmutató:

Kérjük, az összeszerelés megkezdése előtt figyelmesen olvassa el az összes utasítást és információt. Győződjön meg arról, hogy minden alkatrész megvan, amelyre szüksége van az építéshez.

Ügyeljen a biztonságára.

1. Összeszereléskor viseljen védőruházatot és védőkesztyűt, mivel egyes részek élesek lehetnek.
2. Gyerekek és háziállatok nem tartózkodhatnak az építkezésen az összeszerelés során.

Ápolás és karbantartás:

Tisztítsa meg ronggyal és vízzel.

A magyar használati utasítás a gyártótól kapott verzió pontos fordítása.

A kézikönyvben használt fényképek csak illusztrációk, nem egyeznek meg pontosan a termékkel.



Dziękujemy za zakup naszego produktu.

Przed użyciem prosimy o zapoznanie się z niniejszą instrukcją.

Instrukcje Instalacji:

Przed przystąpieniem do montażu prosimy o dokładne zapoznanie się ze wszystkimi instrukcjami i informacjami. Upewnij się, że masz wszystkie części potrzebne do zbudowania.

Zadbaj o swoje bezpieczeństwo.

1. Podczas montażu należy nosić odzież ochronną i rękawice, ponieważ niektóre części mogą być ostre.
2. Podczas montażu nie wolno pozwalać dzieciom ani zwierzętom na poruszanie się po terenie budowy.

Opieka i utrzymanie:

Czyścić szmatką i wodą.

Polska wersja językowa instrukcji jest dokładnym tłumaczeniem oryginalnej instrukcji producenta. Zdjęcia wykorzystane w tym podręczniku są jedynie ilustracją i nie może dokładnie dopasować produkt.



Zahvaljujemo što ste kupili naš proizvod.

Prije uporabe pročitajte ovaj priručnik.

Upute za instalaciju:

Prije početka montaže pažljivo pročitajte sve upute i informacije. Provjerite imate li sve dijelove potrebne za izgradnju.

Vodite računa o svojoj sigurnosti.

1. Nosite zaštitnu odjeću i rukavice prilikom sastavljanja jer neki dijelovi mogu biti oštri.
2. Djeci i kućnim ljubimcima ne smije se dopustiti da lutaju gradilištem tijekom montaže.

Njega i održavanje:

Očistite krpom i vodom.

Hrvatska verzija priručnika točan je prijevod originalnih uputa proizvođača.

Slike korištene u ovom priručniku služe samo za ilustraciju i mogu se razlikovati od stvarnog proizvoda.



Zahvaljujemo se vam za nakup našega izdelka.

Pred uporabo preberite ta priručnik.

Navodila za namestitev:

Pred začetkom montaže natančno preberite vsa navodila in informacije. Prepričajte se, da imate vse dele, ki jih potrebujete za gradnjo.

Poskrbite za svojo varnost.

1. Pri sestavljanju nosite zaščitno obleko in rokavice, saj so lahko nekateri deli ostri.
2. Otroci in hišni ljubljenci se med montažo ne smejo sprehajati po gradbišču.

Nega in vzdrževanje:

Očistite s krpo in vodo.

Slovenska različica navodil za uporabo je natančen prevod originalnih proizvajalčevih navodil. Fotografije, uporabljene v navodilih, so samo ilustrativne in se morda ne ujemajo popolnoma z izdelkom.



EN Installation

DE Montage

CZ Montáž

SK Montáž



















































HU Összeszerelés

PL Montaż

HR Sastavljanje

SLO Montáž

EN Parts list**DE** Teilleiste**CZ** Seznam dílů**SK** Zoznam dielov**HU** Alkatrész lista**PL** Wykaz części**HR** Popis dijelova**SL** Seznam delov

#		mm	PCS	#		mm	PCS	
GYC-A1		765	x2	GY-20			x2	
GY-21		1800	x2	GY-22			x1	
GY-22		300	x2	GY-23			x1	
GYC-C5		1891	x1	GY-23a			x1	
GYC-C6		1891	x1	GY-15			x2	
GY-23		1891	x1	GY-16a			x2	
GY-24		1891	x1	GYT-21			x98	
GY-25		1855	x1	GYC-LF30		M8x10	x12	
GY-26		1855	x1	GYC-LF31		M8	x12	
GY-27		2006	x1	GYC-LF32		ST5x35	x8	
GY-28		2006	x1	GYC-LF33		ST5x14	x6	
GY-29			400	x1	GYC-LF34		ST4.8x16	x196
GY-30			800	x3	GYC-LF35		M5x19	x50
GY-31		1888.5	x2	GYC-LF36		M5	x50	
GY-32		800	x1	GYC-LF37		M6x40	x6	
GY-33		1751.5	x2	GYC-LF38		M6	x4	
GY-34		1902.5	x2	GYC-LF39		M6	x6	
GY-35		1855	x2	GYC-LF40		M10	x100	
GY-36		2006	x2	GYC-LF41		ST4x10	x200	
GY-37		1813	x2	GYC-LF42		M8x70	x16	
GY-38		1964	x2	GYC-LF43		Ø6	x50	
GY-39		1855	x4	GYC-LF44		M4x10	x16	
GY-40		1845	x50	GYC-LF45		M4	x16	
GY-41		160	x2	GYC-LF46			x100	
GY-42			x48	GYC-LF47		M8x12	x16	
GY-43			x50					
GY-44			x2					
GY-45			x90					
GY-46			x2					
GY-47			x8					
GY-48			x4					
GYC-13			x2					
GY-14			x2					
GYC-14			x2					
GY-18			x2					

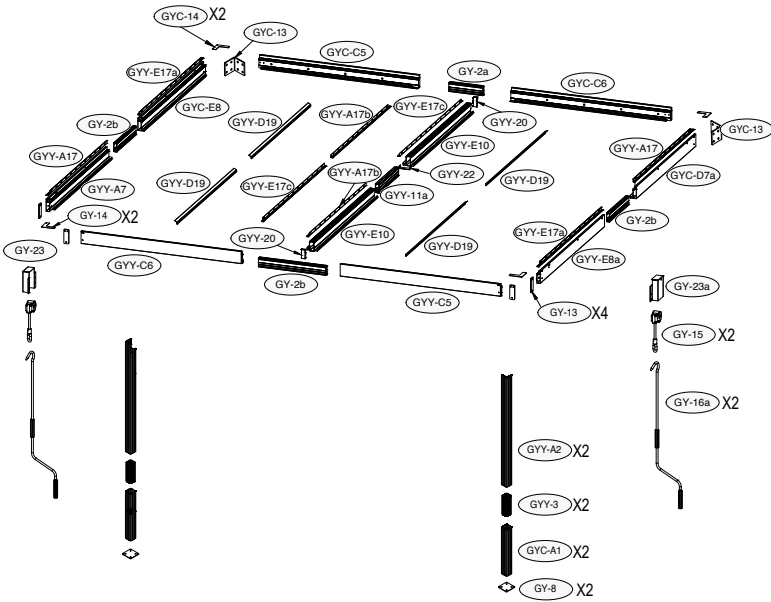
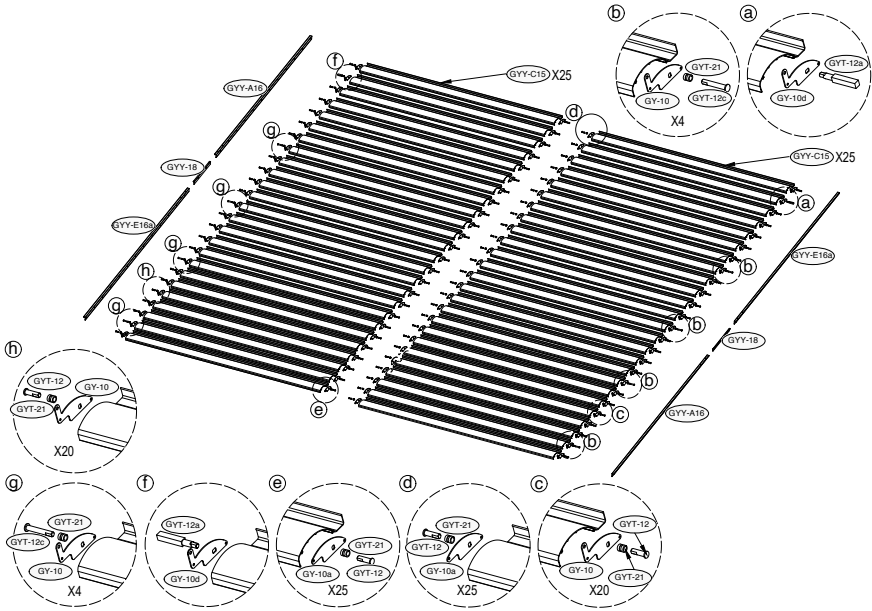

EN Tools you will need

CZ Nástroje, které budete potřebovat

HU Szükséges eszközök és szerszámok

HR Alati koji će vam trebati

DE Werkzeuge, die Sie brauchen

SK Nástroje, ktoré budete potrebovať

PL Przystroje i narzędzia, które będą potrzebne

SLO Orodja, ki jih boste potrebovali

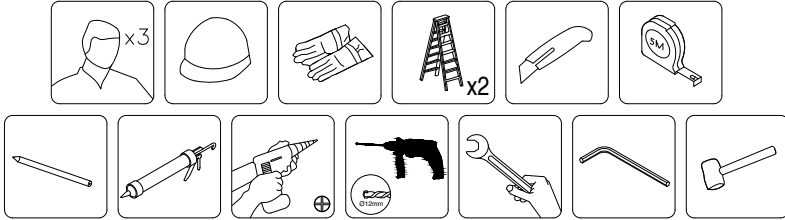

EN Dimensions

DE Abmessungen

CZ Rozměry

SK Rozmery

HU Méretek

PL Wymiary

HR Dimenzije

SLO Dimenzije

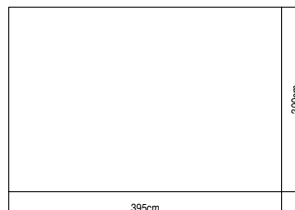
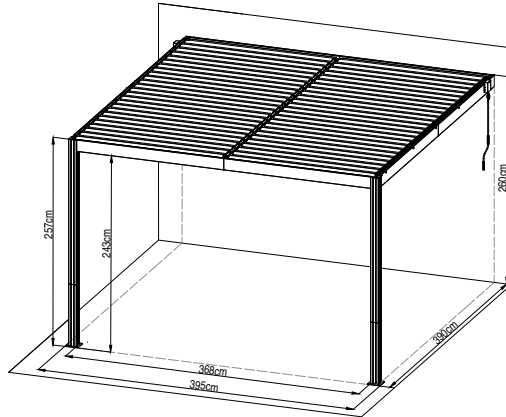

EN Assembly instructions

DE Montageanleitung

CZ Návod k montáži







SK Návod k montáži

HU Szerelési útmutató

PL Instrukcja montażu

HR Upute za montažu

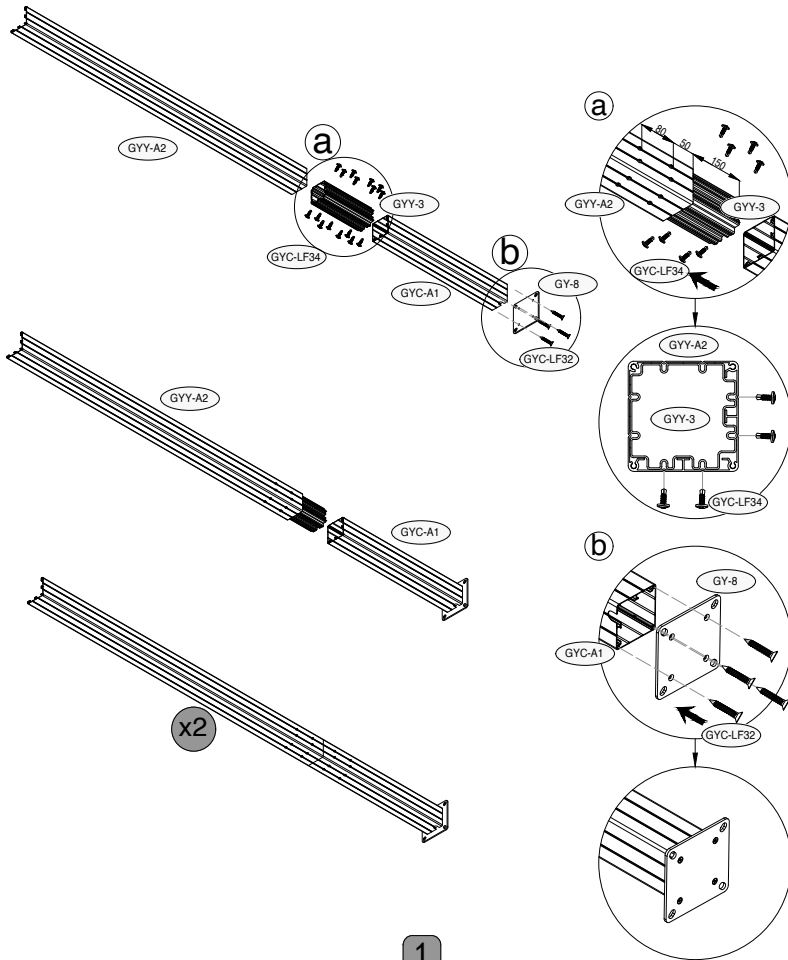

SLO Navodila za namestitev

1	 GYC-A1 x2	 GYY-A2 x2	 GYY-3 x2	 GY-8 x2	 GYC-LF32 x8	 GYC-LF34 x32
----------	---	---	--	---	---	--

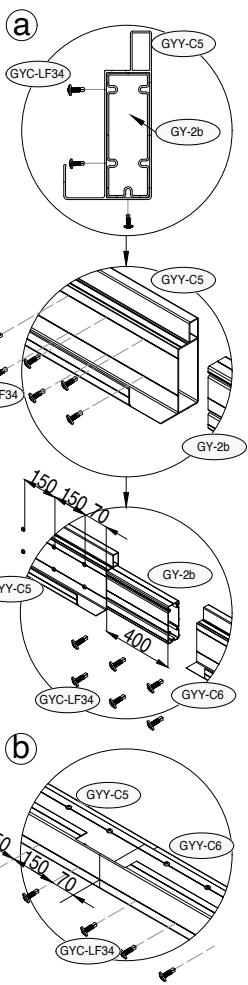
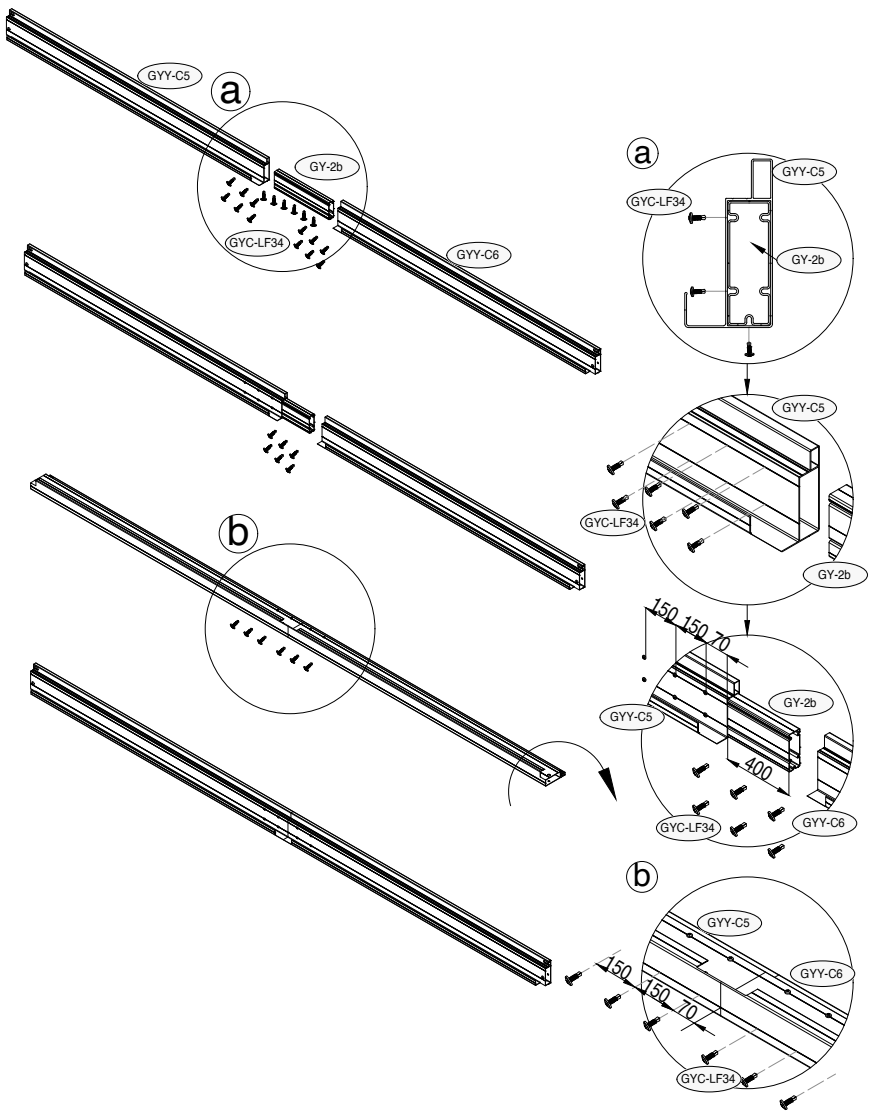

2	 GY-Y-C5 x1	 GY-Y-C6 x1	 GY-2b x1	 GYC-LF34 x18
----------	---	---	---	---



3	 GY-13 x2	 GYC-LF30 x6	 GYC-LF31 x6	
----------	--	---	---	--

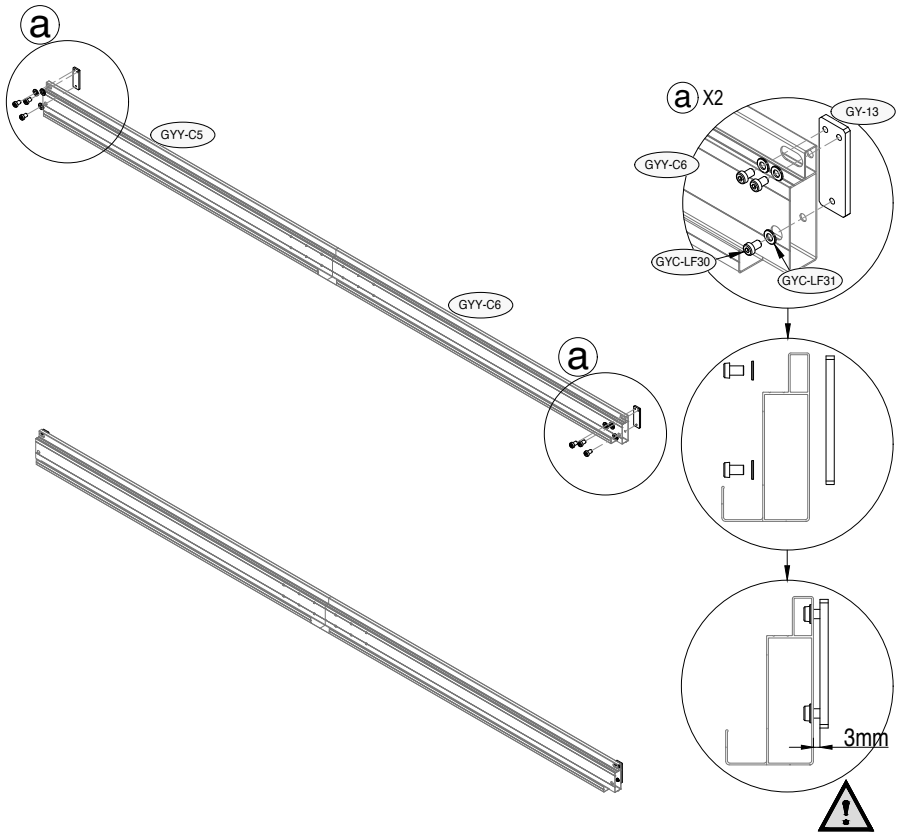



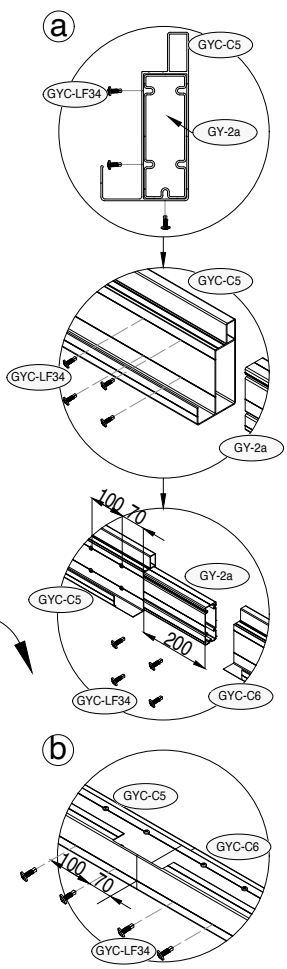
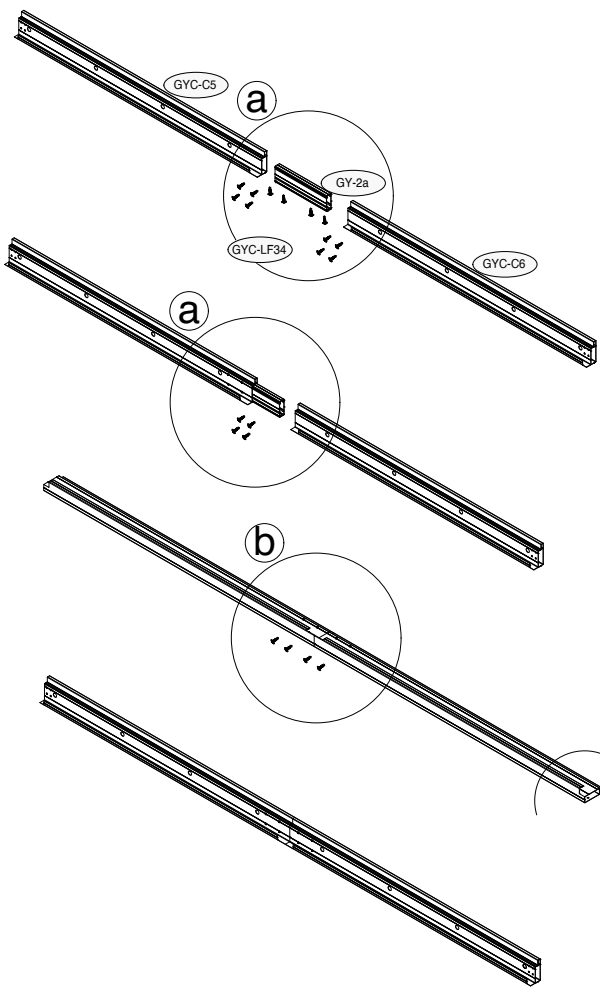

4	 GYC-C5 x1	 GYC-C6 x1	 GY-2a x1	 GYC-LF34 x12	
----------	--	--	---	---	--

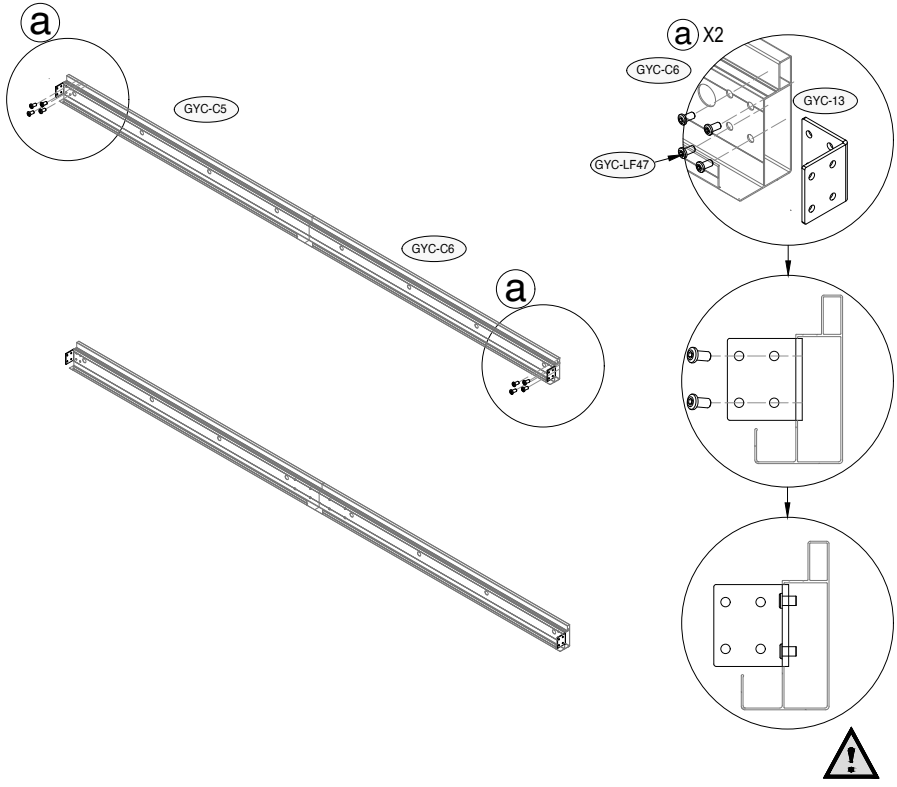



5	 GYC-13 x2	 GYC-LF47 x8	
----------	--	--	--

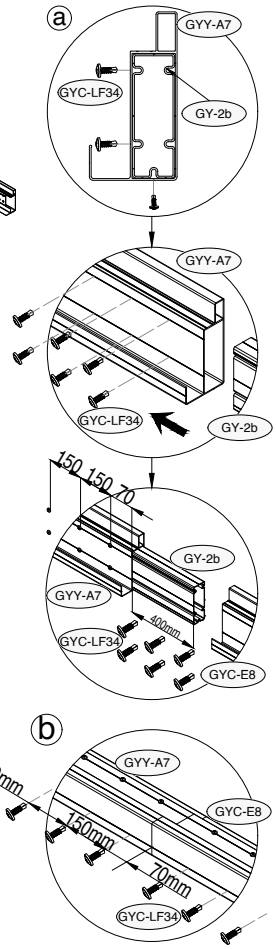
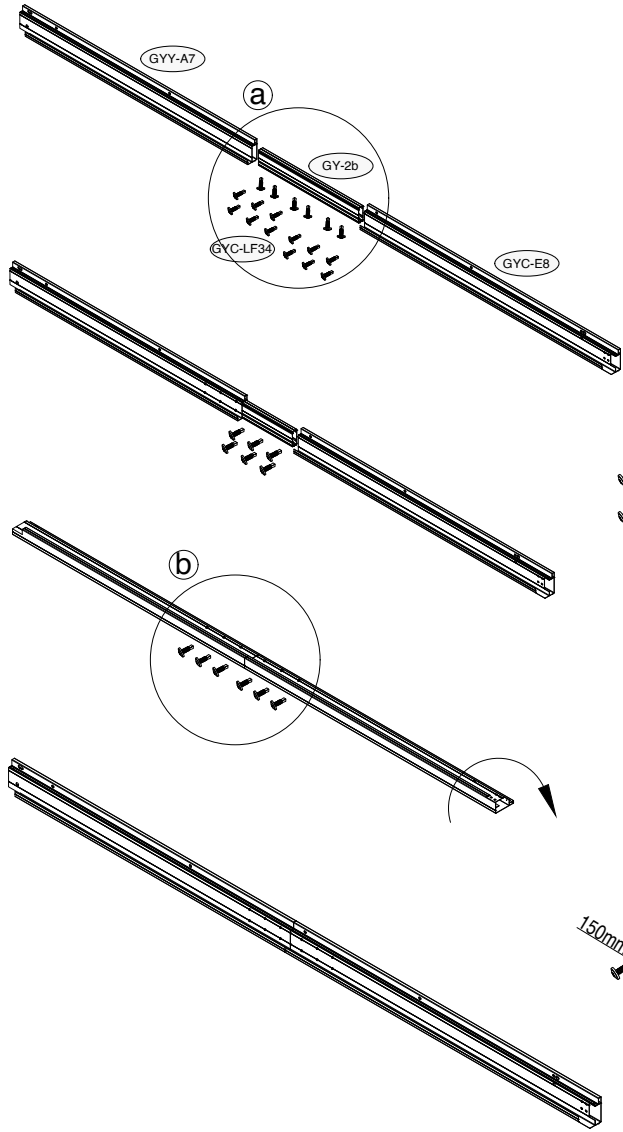

6	 GY-Y-A7 x1	 GY-C-E8 x1	 GY-2b x1	 GY-C-LF34 x18	
----------	---	---	---	--	--



7	 GY-13 x1	 GYC-LF30 x3	 GYC-LF31 x3	
----------	---	--	--	--

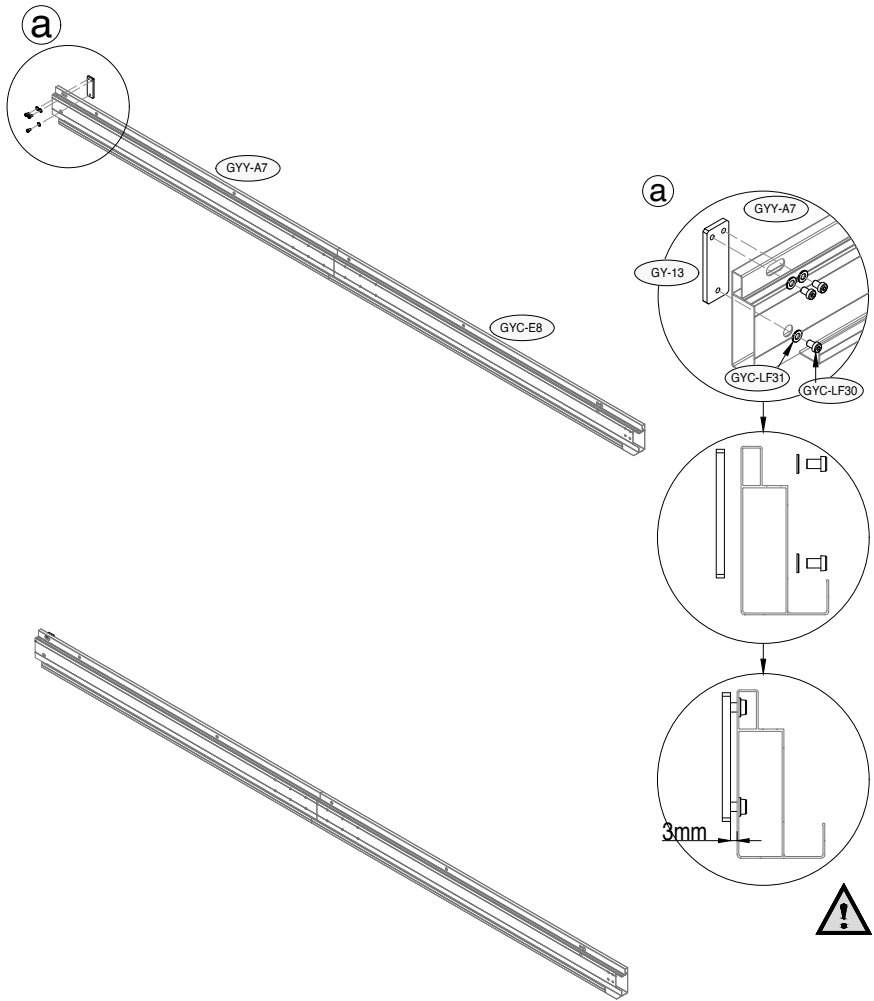



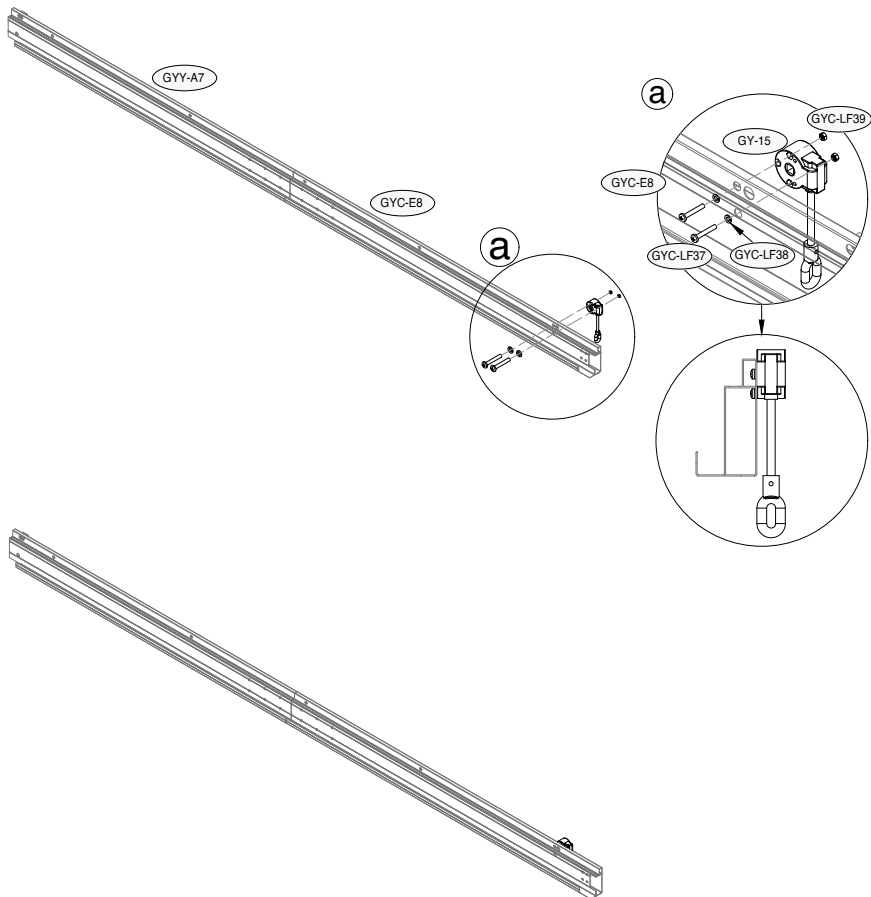

8	 GY-15 x1	 GYC-LF37 x2	 GYC-LF38 x2	 GYC-LF39 x2	
----------	---	--	--	--	--

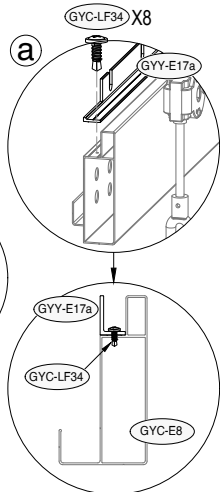
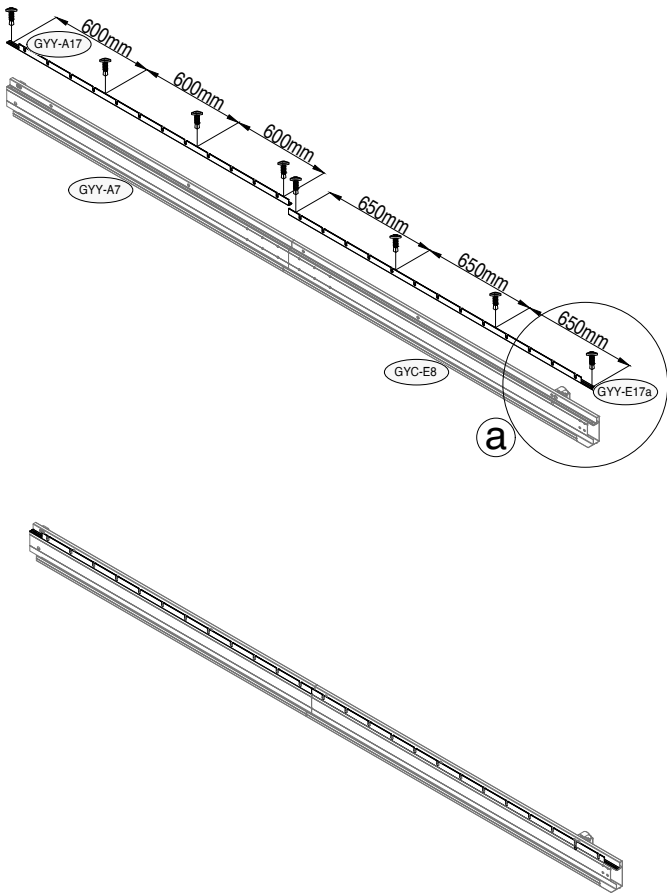



9	L	L		
	GY-Y-A17 x1	GY-Y-E17a x1	GYC-LF34 x8	

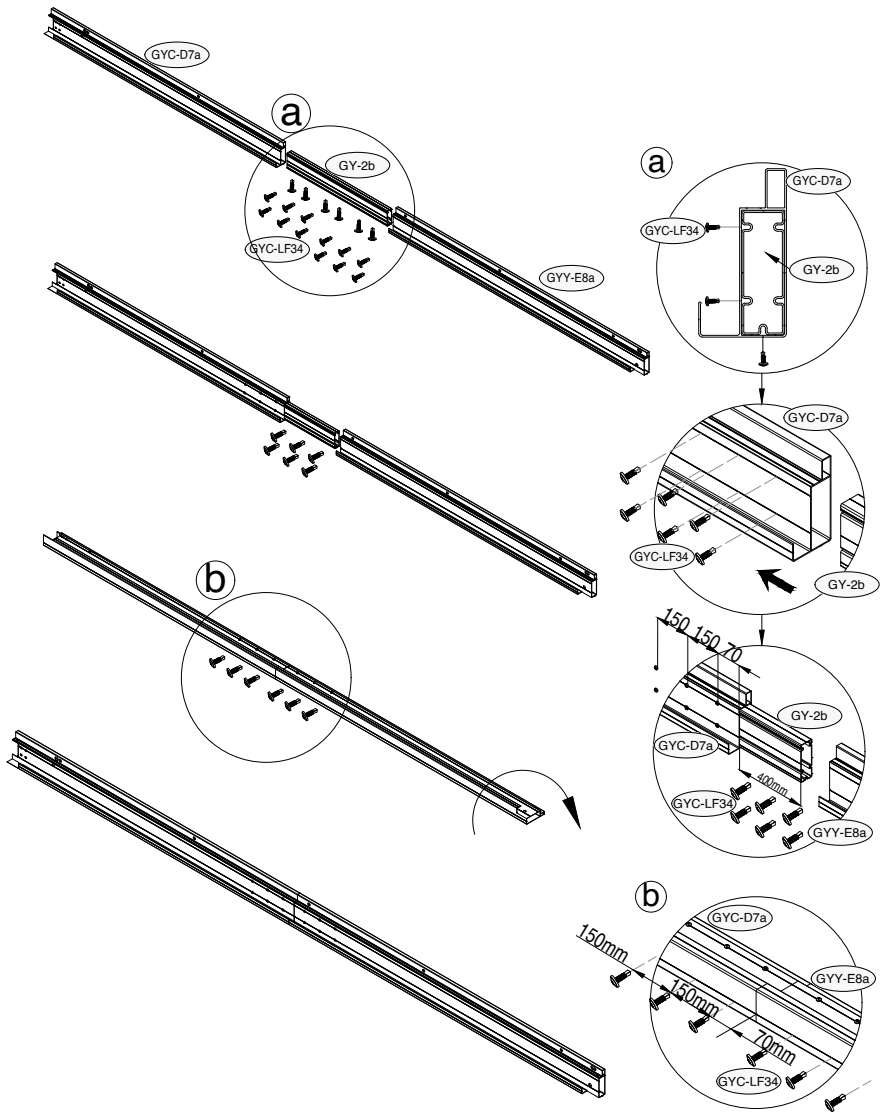

10	 GYC-D7a x1	 GYE-E8a x1	 GY-2b x1	 GYC-LF34 x18	
-----------	---	---	---	---	--



11	 GY-13 x1	 GYC-LF30 x3	 GYC-LF31 x3	
-----------	---	--	--	--

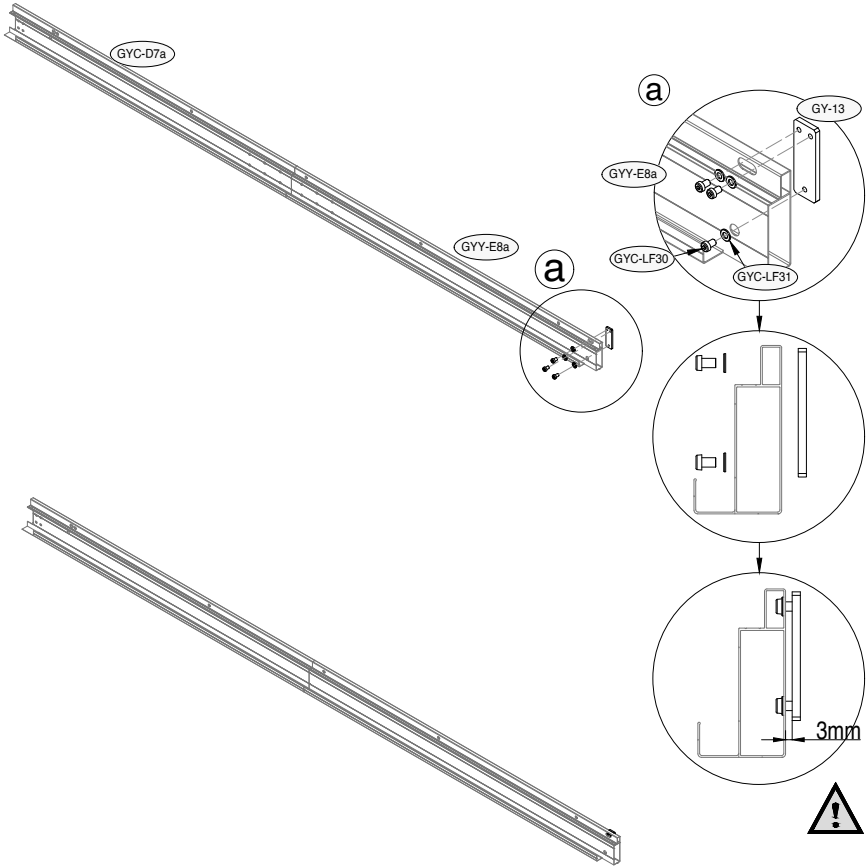

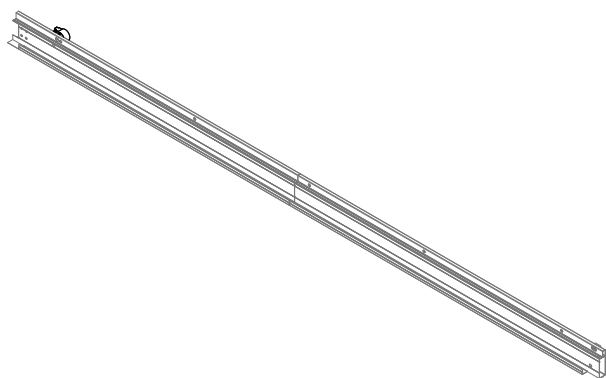
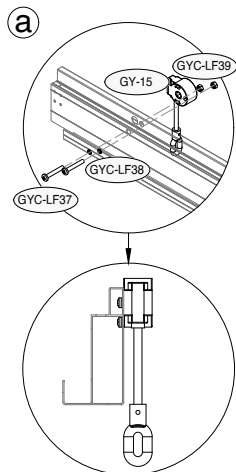
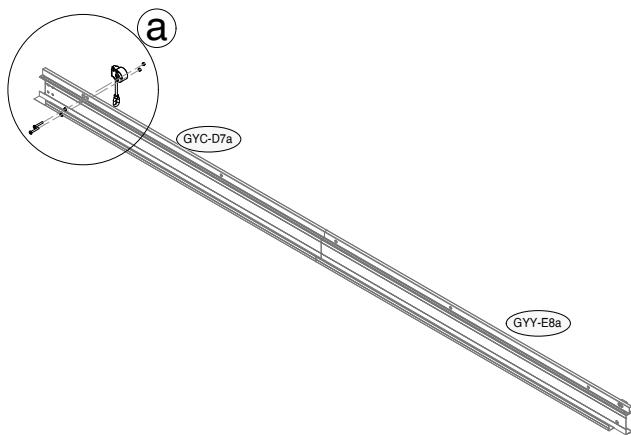

12	 GY-15 x1	 GYC-LF37 x2	 GYC-LF38 x2	 GYC-LF39 x2	
-----------	---	--	--	--	--



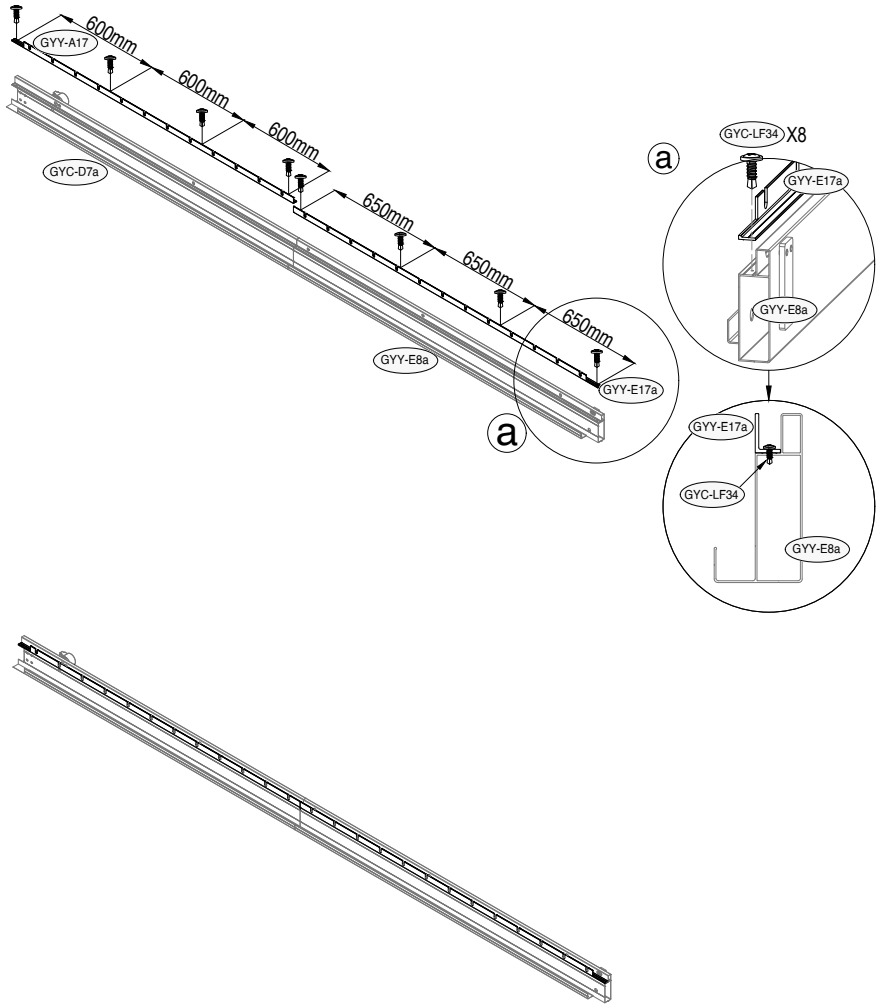

<p>13</p>	 <p>GY-Y-A17 x1</p>	 <p>GY-Y-E17a x1</p>	 <p>GY-C-LF34 x8</p>	
------------------	--	---	---	--

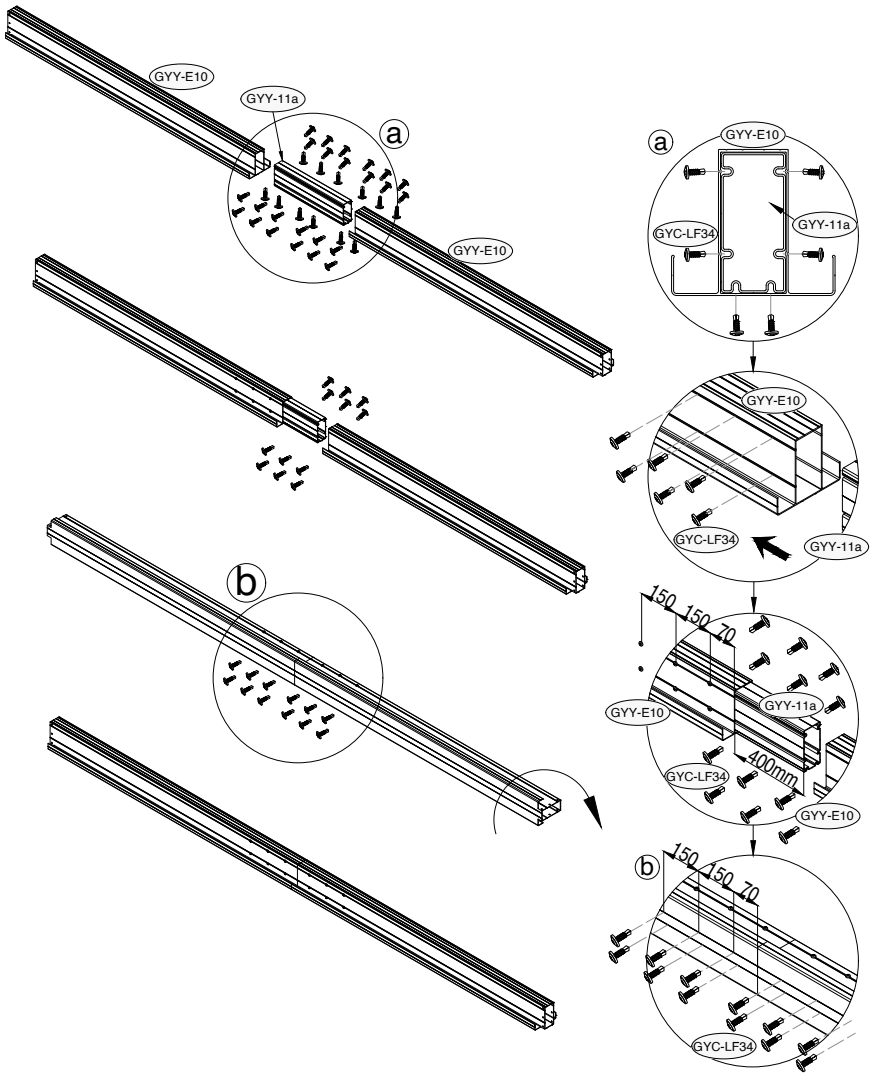

14	 GYE-E10 x2	 GYE-11a x1	 GYC-LF34 x36	
-----------	---	---	---	--



15				
	GYE-A17b x2	GYE-E17c x2	GYC-LF34 x16	

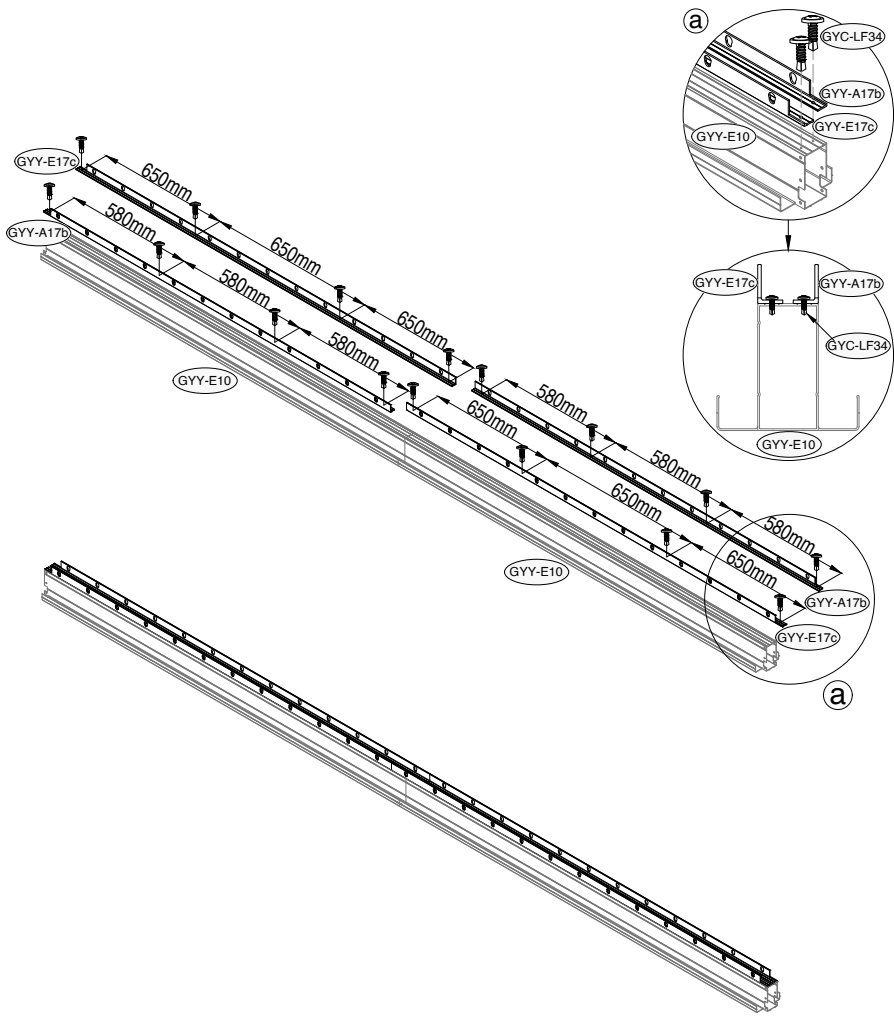

16



GYY-20 x2



GYC-LF34 x12

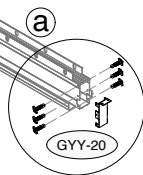
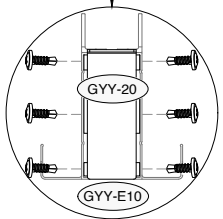
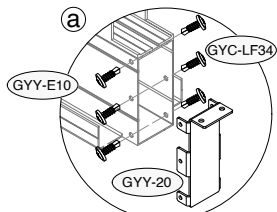
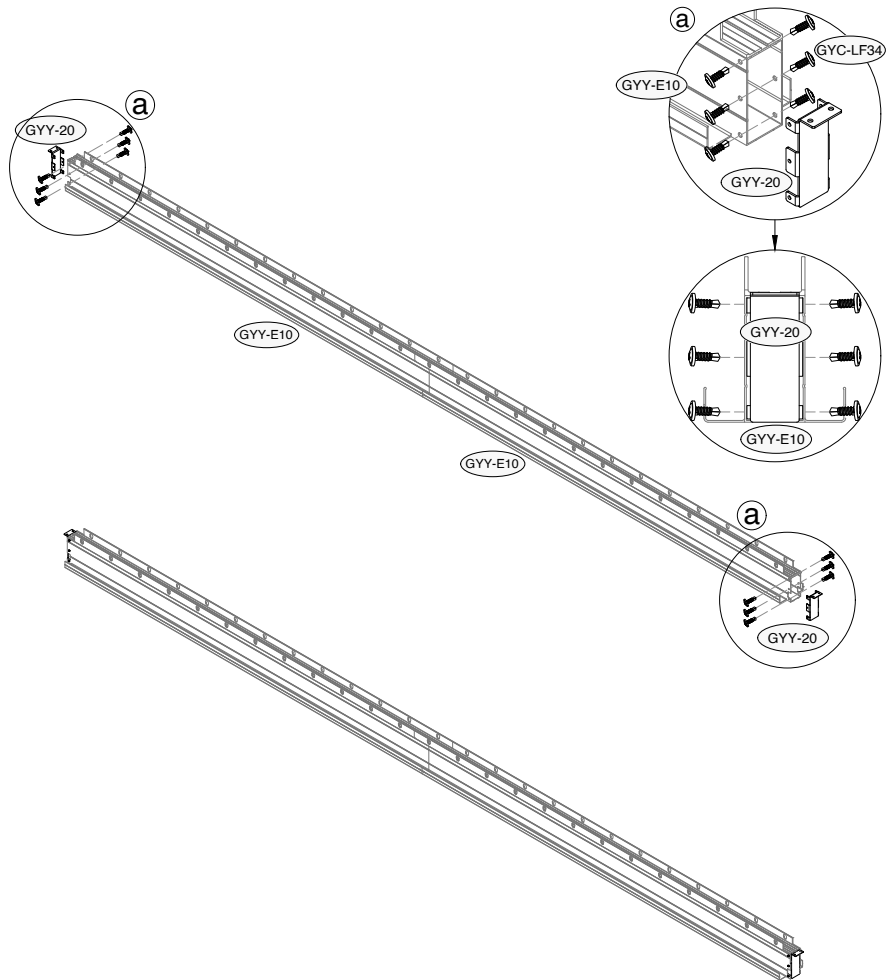

17

GYC-LF42 x8

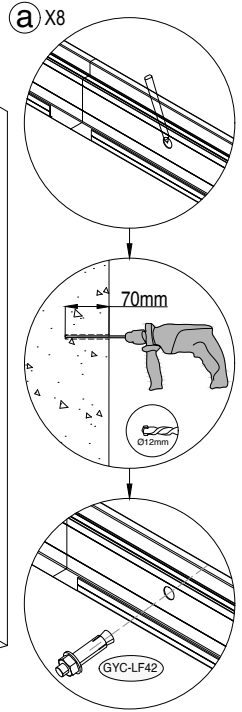
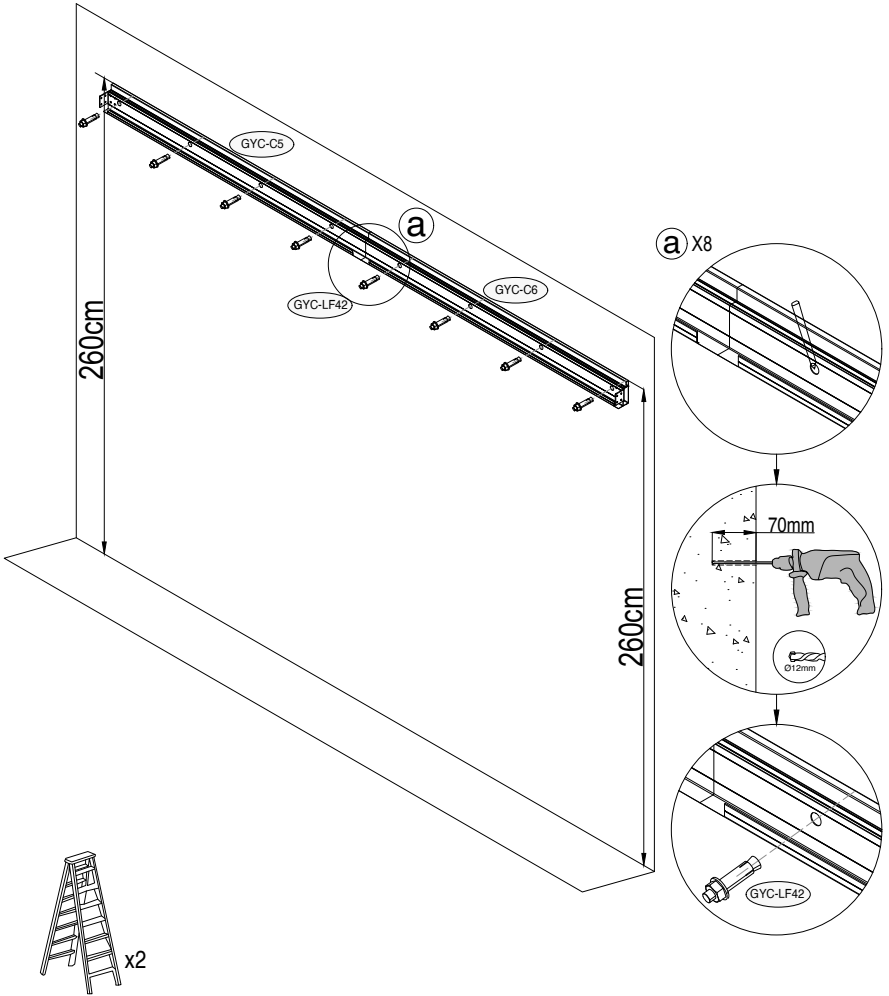

17

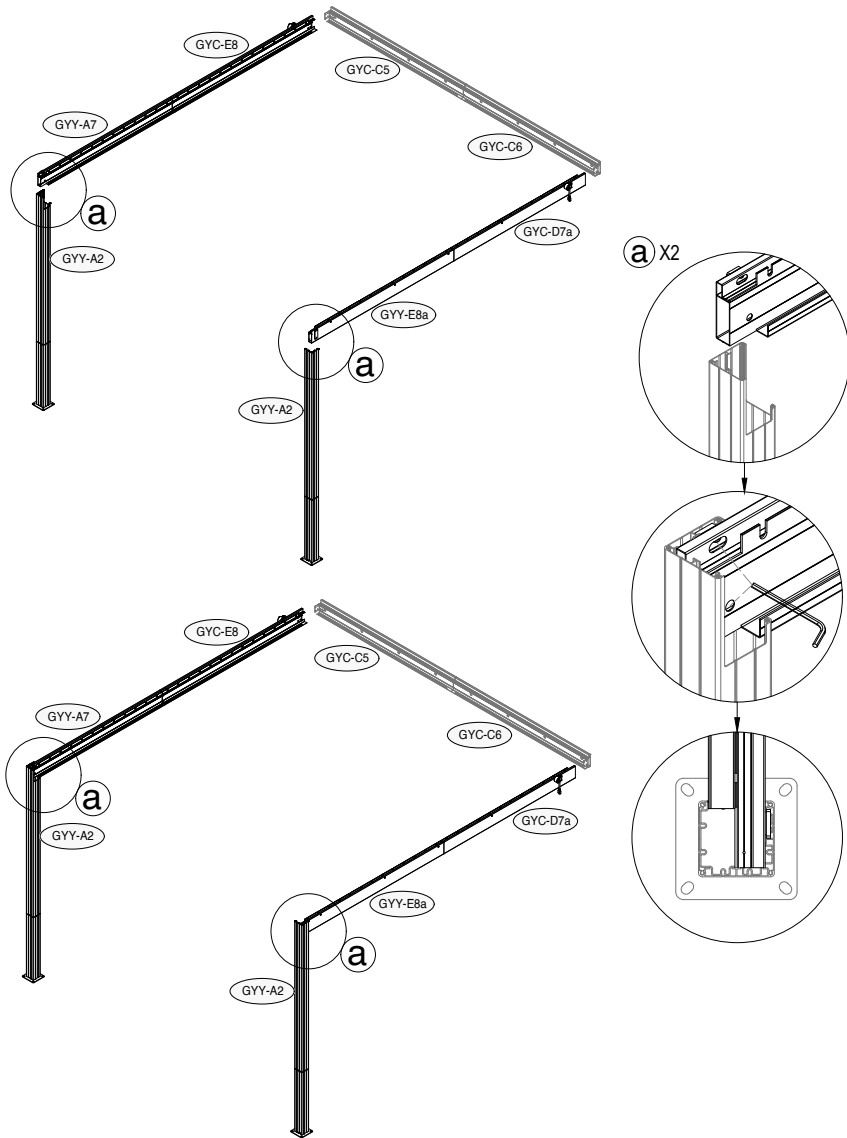

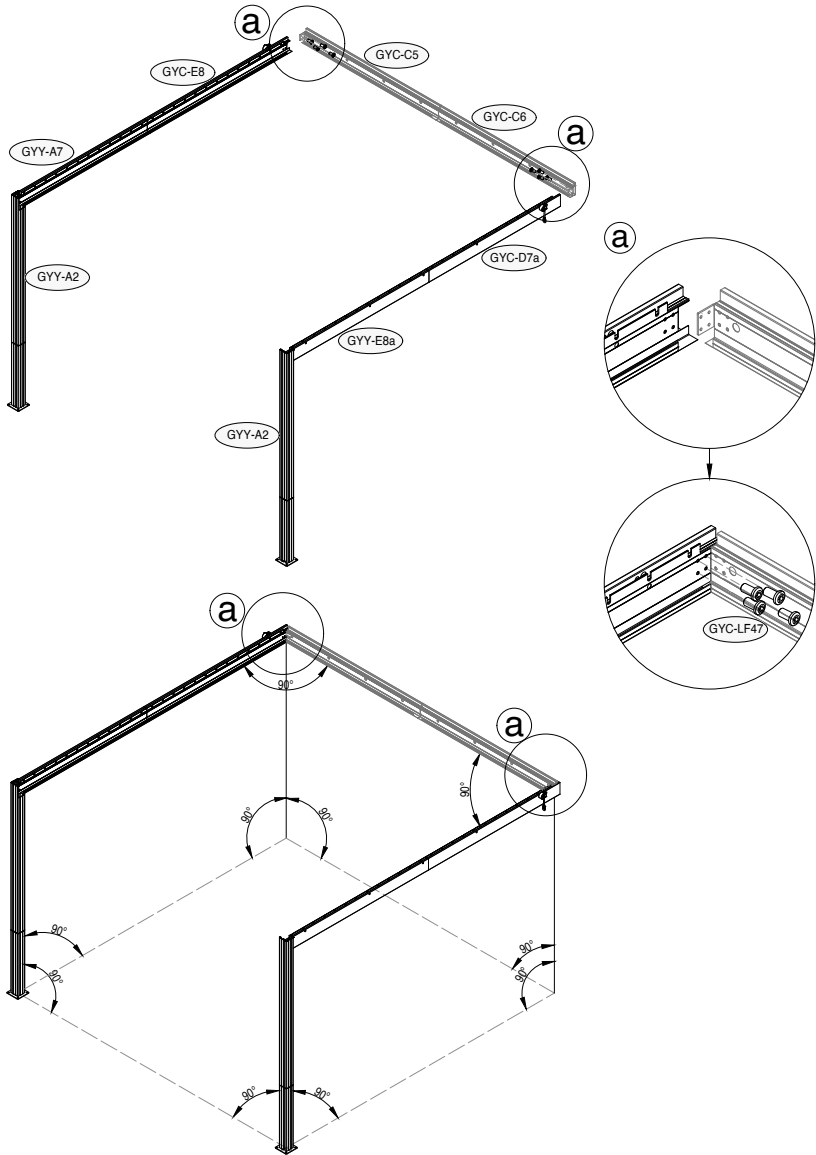

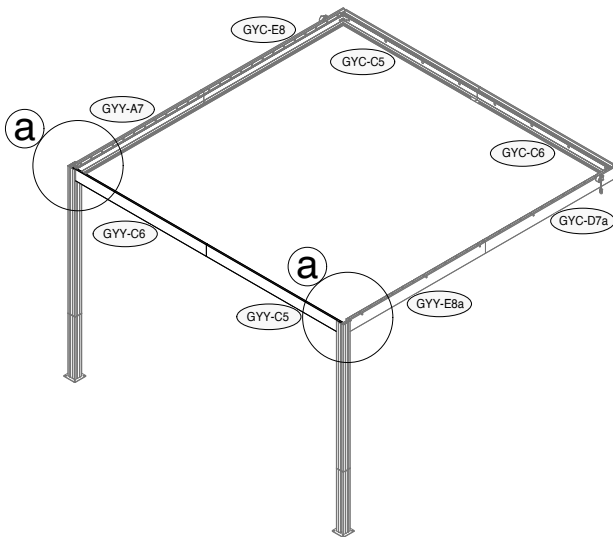
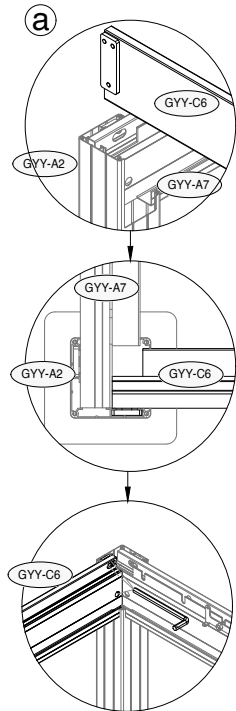
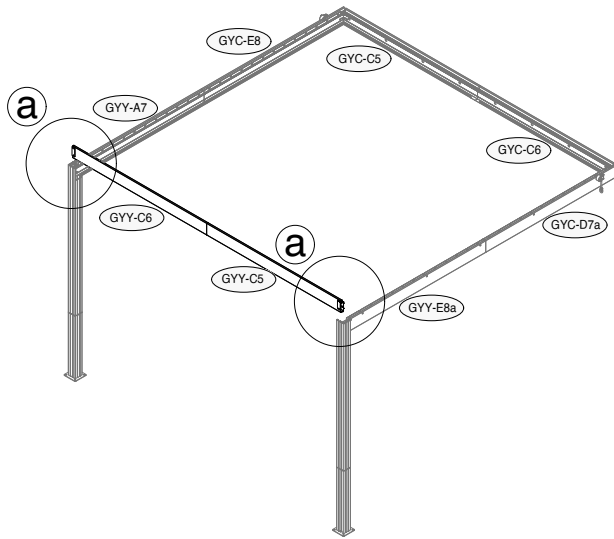

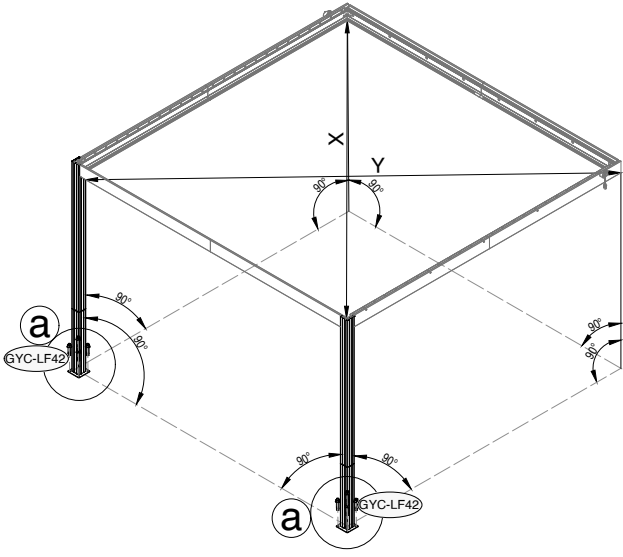

21

GYC-LF42 x8



 X=Y=534cm

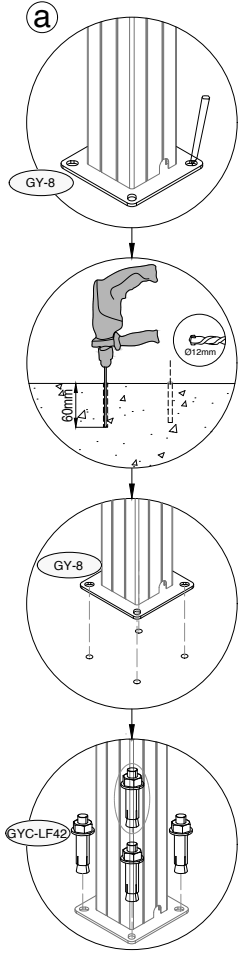
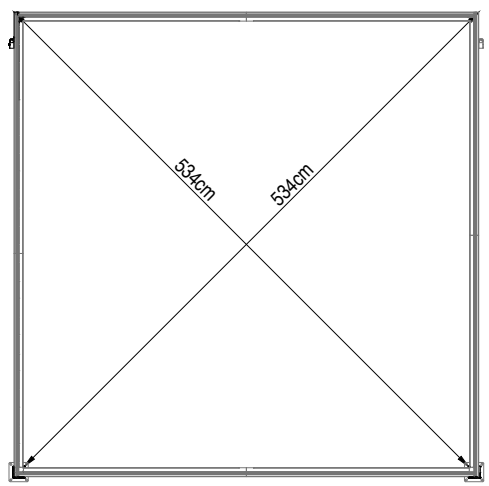

21

22

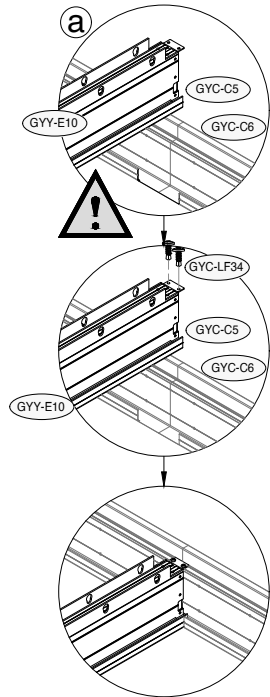
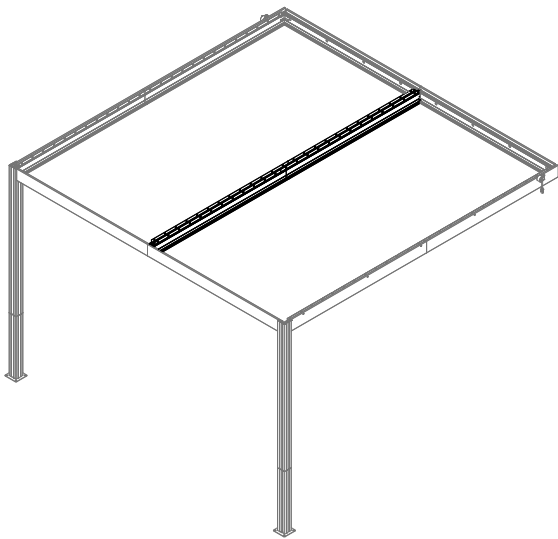
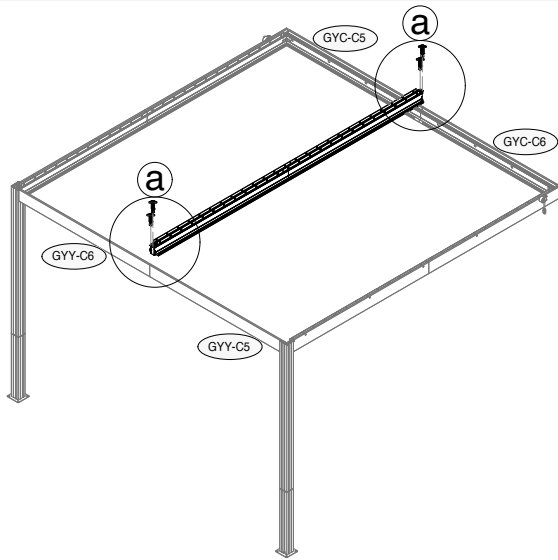

GYC-LF34 x4



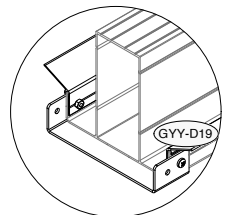
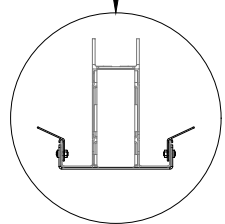
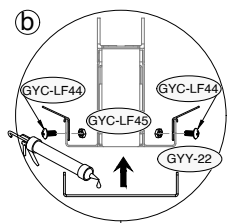
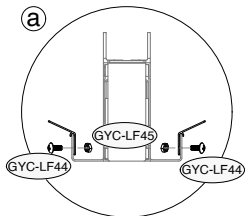
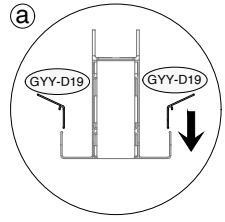
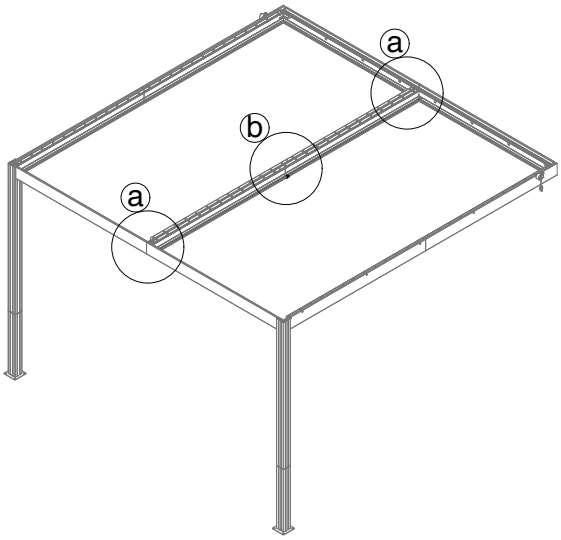
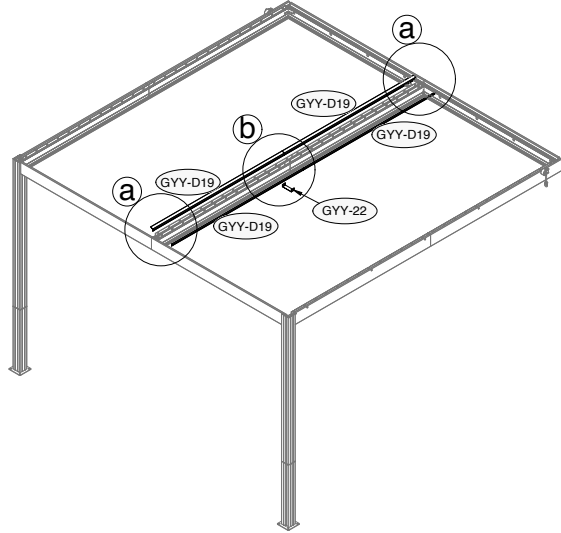

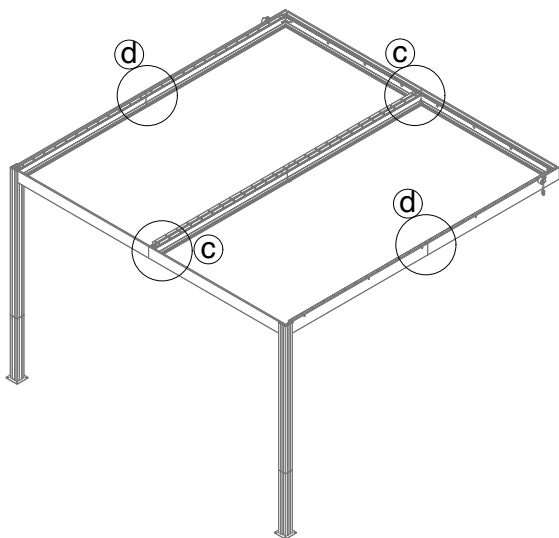
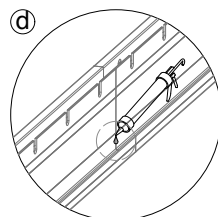
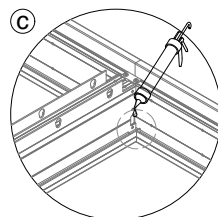
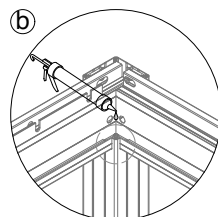
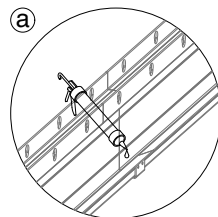
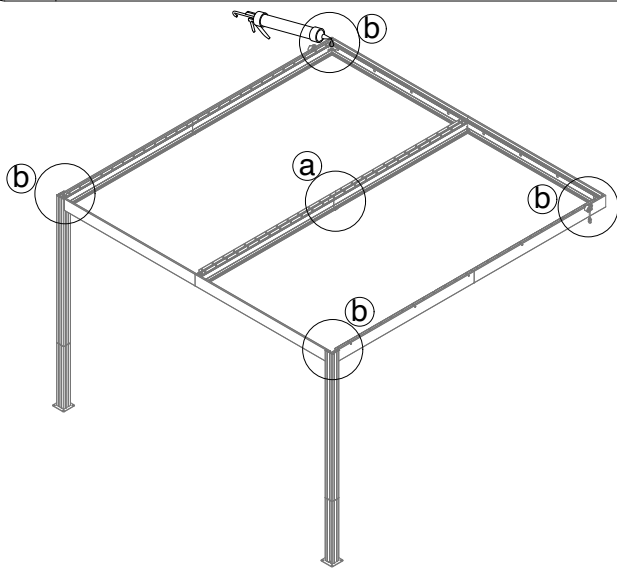

23	 GY-Y-D19 x4	 GY-Y-22 x1	 GY-C-LF44 x8	 GY-C-LF45 x8
-----------	--	---	---	---



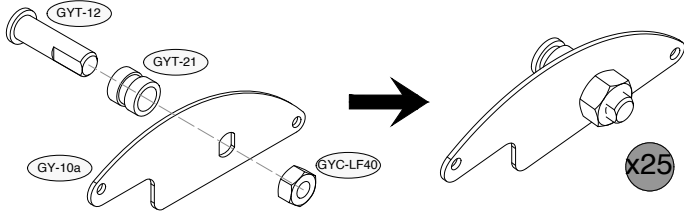

25				
	GY-10a x25	GYT-12 x25	GYT-21 x25	GYC-LF40 x25



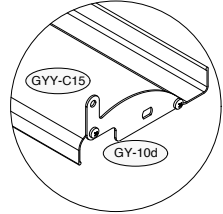
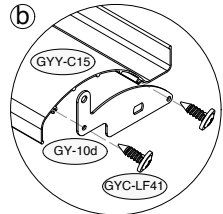
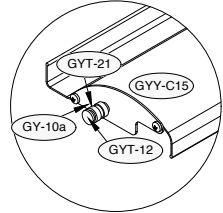
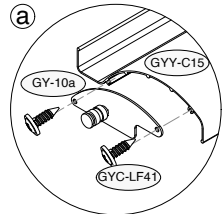
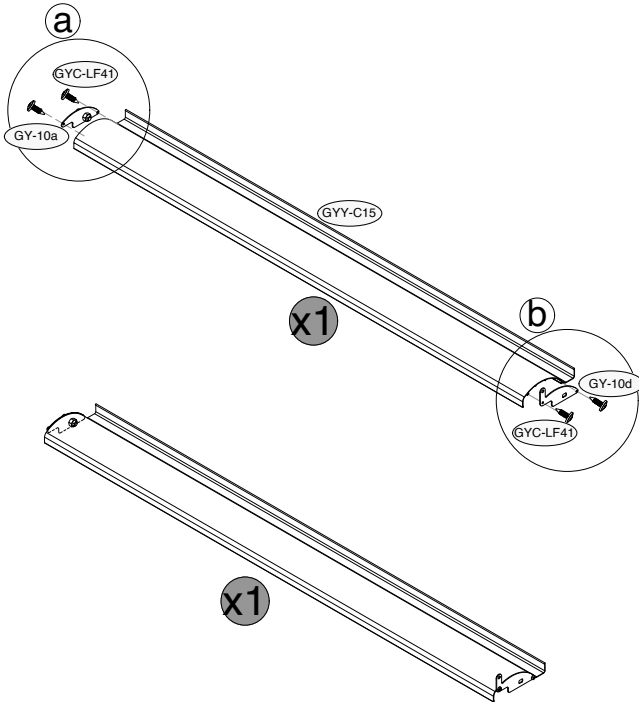

		
GY-10d x1	GY-10d x1	GYC-LF41 x4



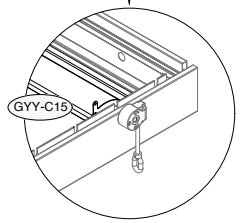
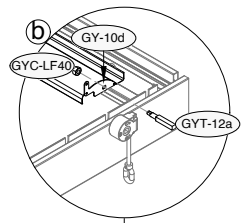
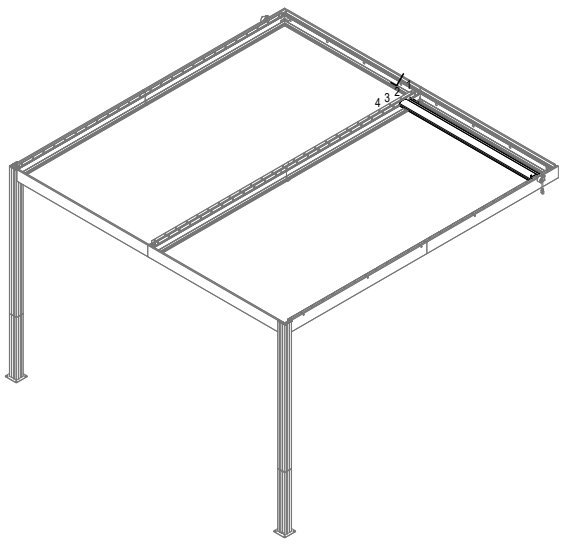
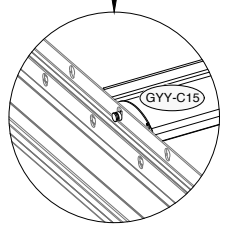
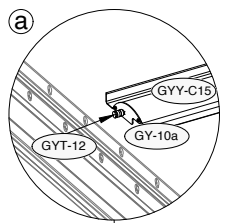
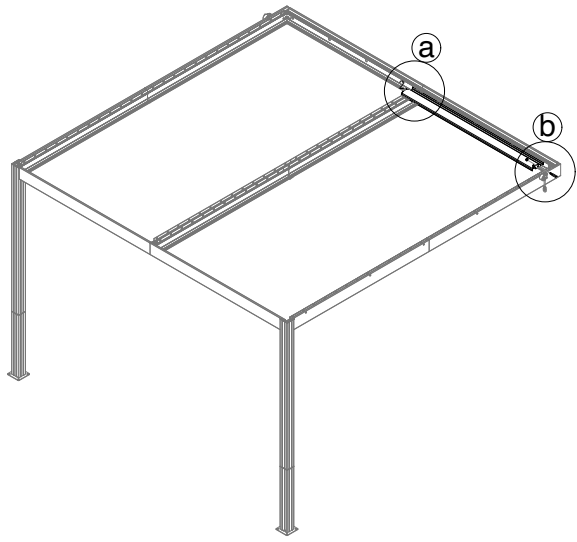

26		
	GYT-12a x1	GYC-LF40 x1



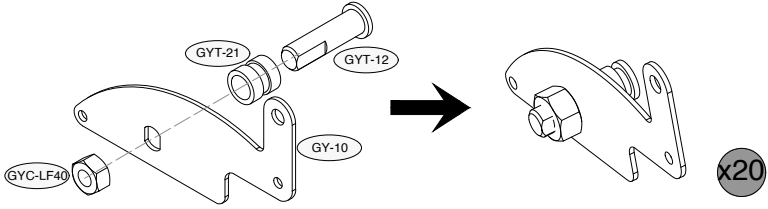

27	 GY-10 x20	 GYT-12 x20	 GYT-21 x20	 GYC-LF40 x20
-----------	--	---	---	---

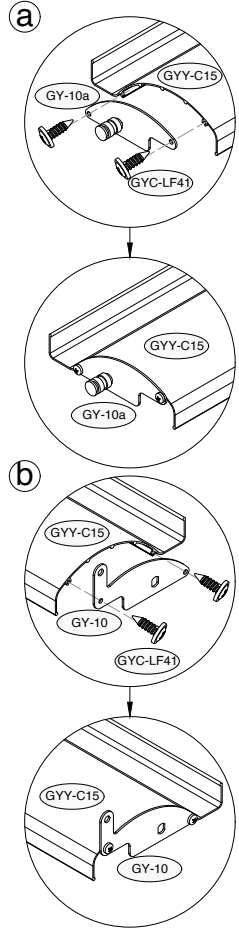
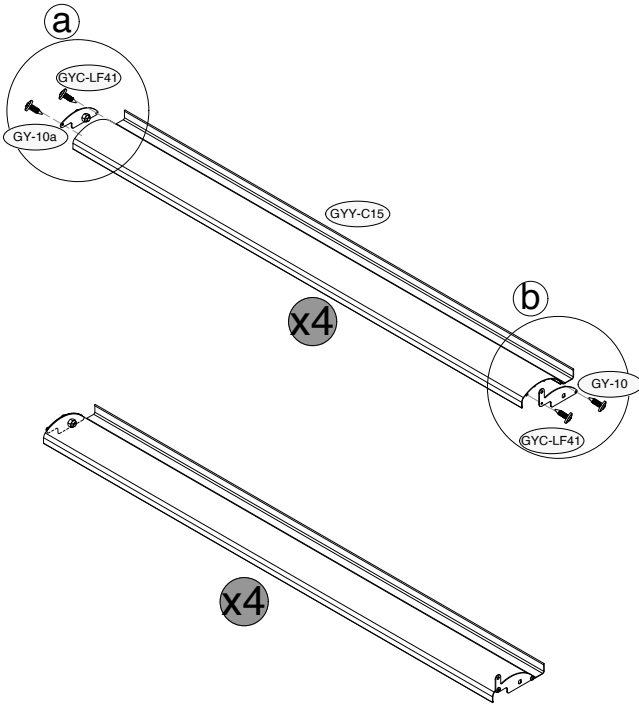

 GY-10 x4	 GYY-C15 x4	 GYC-LF41 x16
---	---	---



28	 GYT-12c x4	 GYT-21 x4	 GYC-LF40 x4	
-----------	--	---	---	--

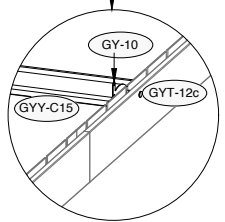
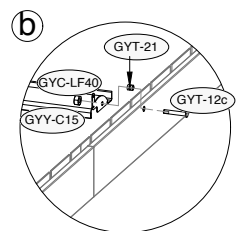
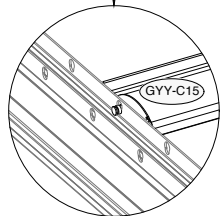
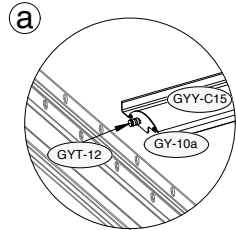
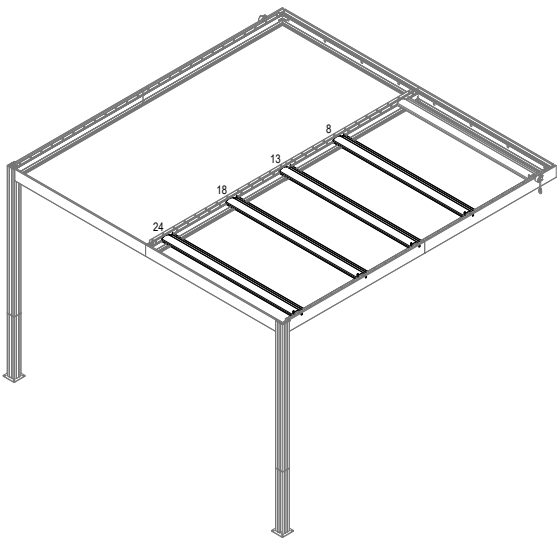
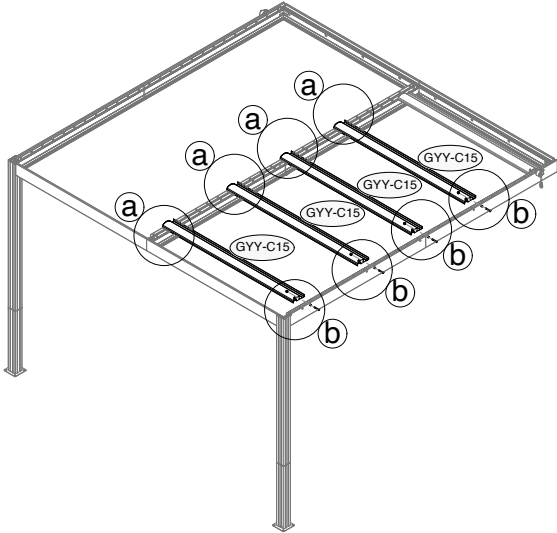

29

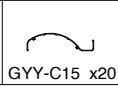



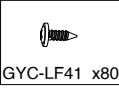

GY-Y-C15 x20

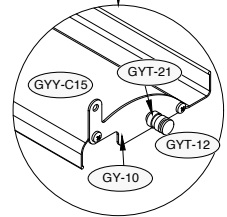
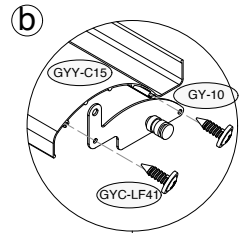
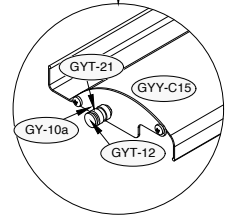
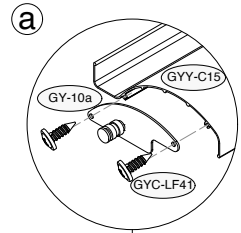
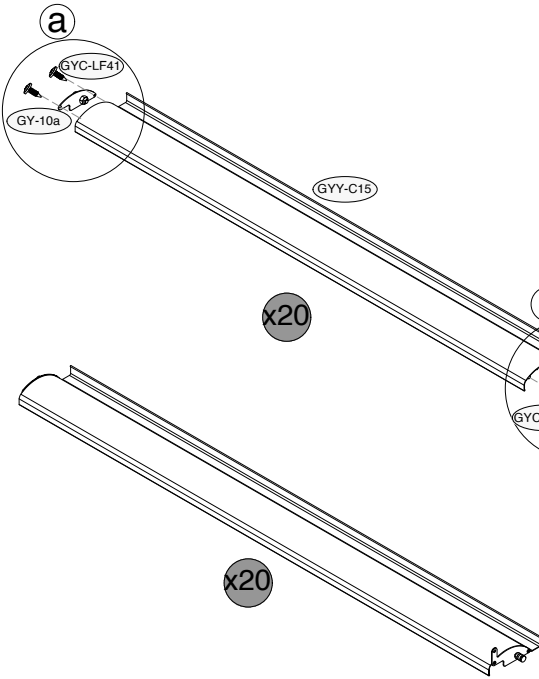

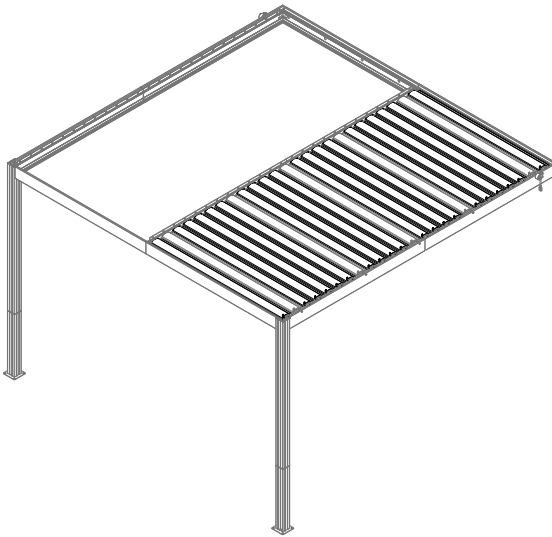
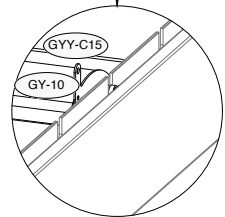
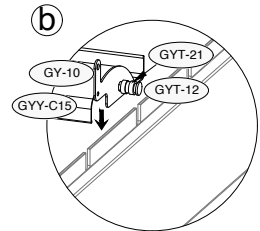
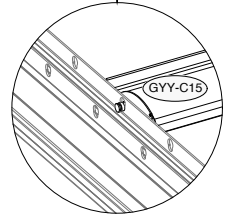
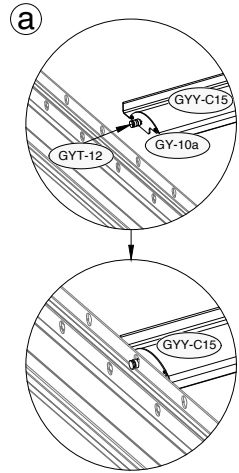
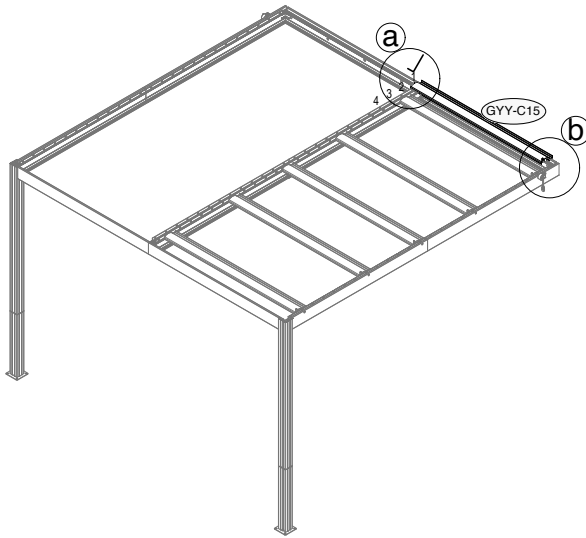



GY-C-LF41 x80



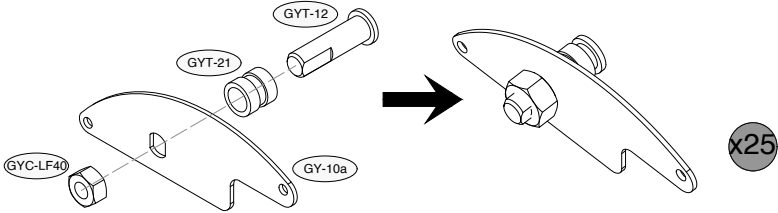

31					
	GY-10a x25	GYT-12 x25	GYT-21 x25	GYC-LF40 x25	



		
GY-10d x1	GYY-C15 x1	GYC-LF41 x4

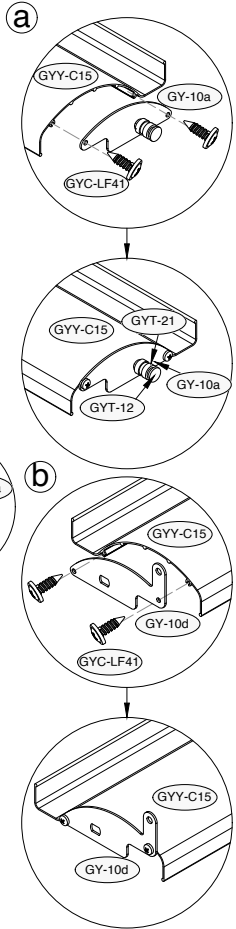
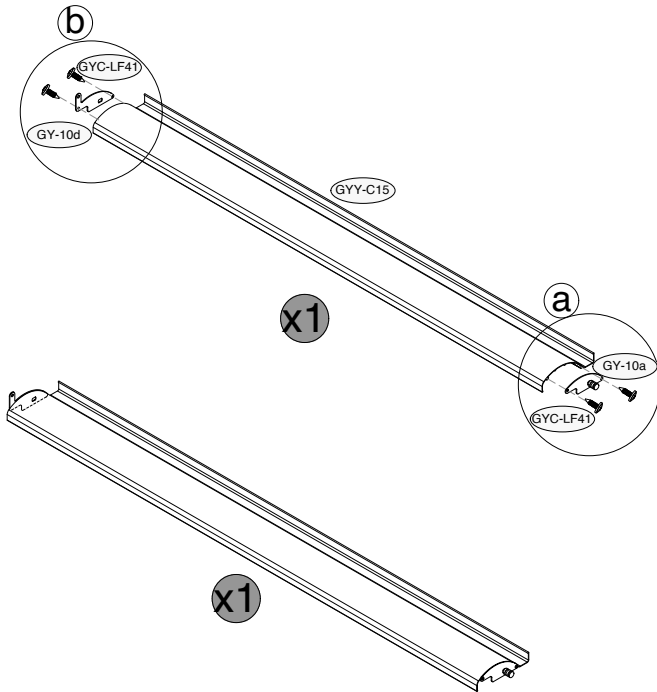

32



GYT-12a x1



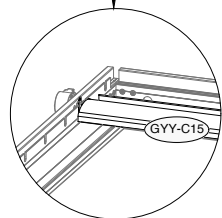
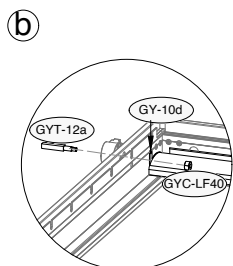
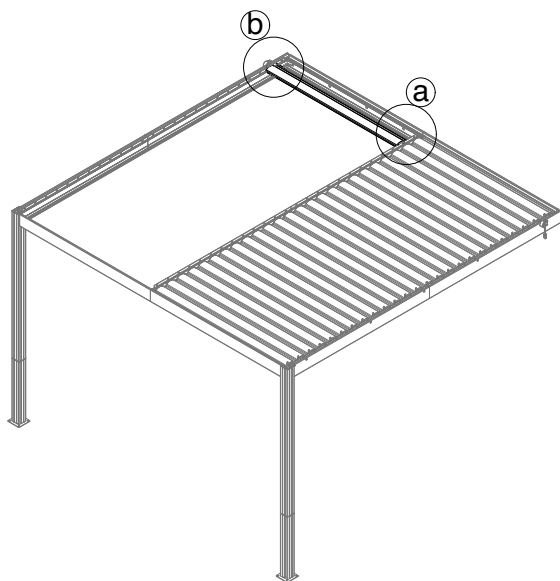
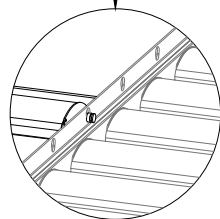
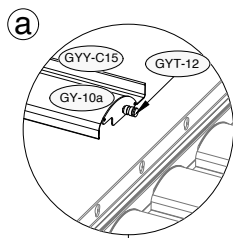
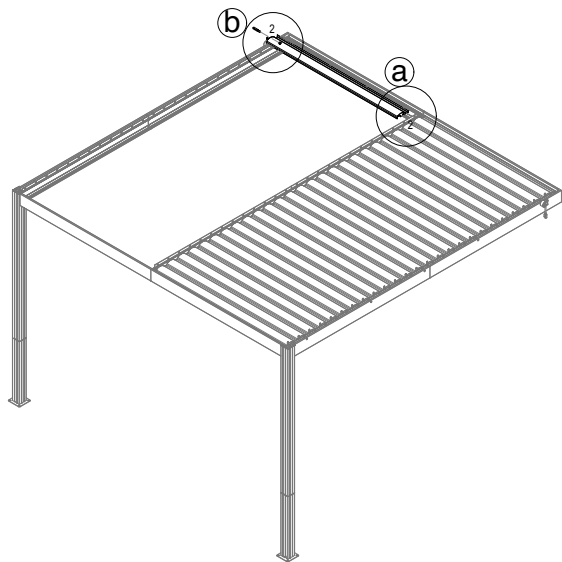

GYC-LF40 x1



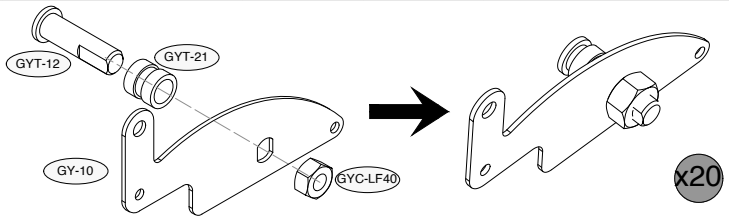

33					
	GY-10 x20	GYT-12 x20	GYT-21 x20	GYC-LF40 x20	

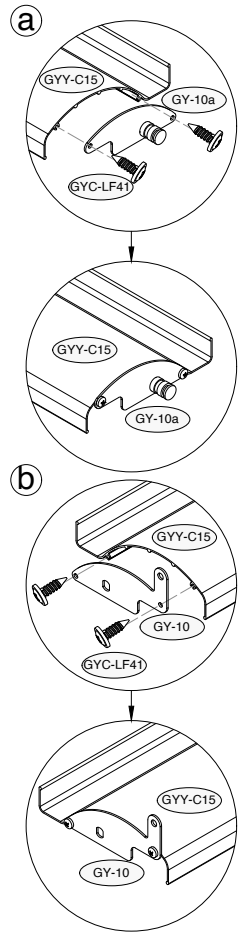
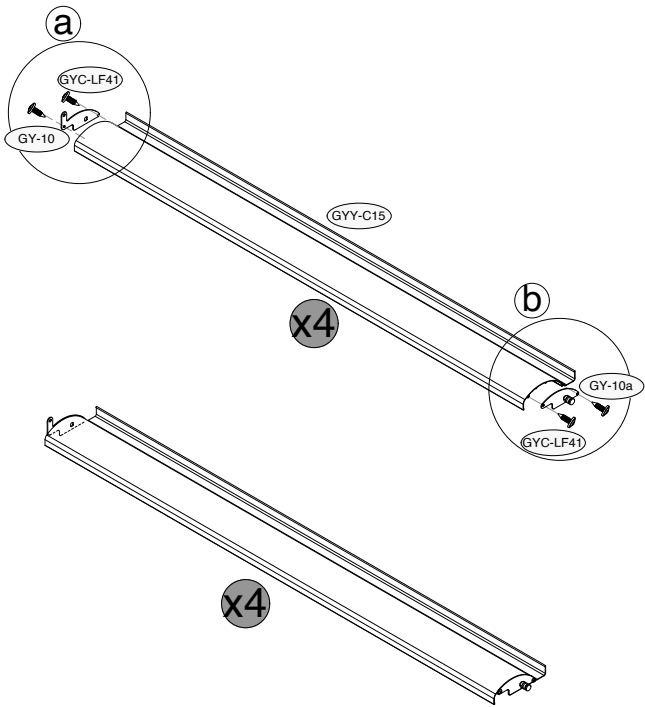

		
GY-10 x4	GY-10a x4	GYC-LF41 x16





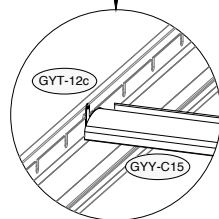
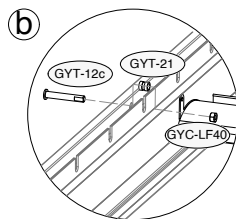
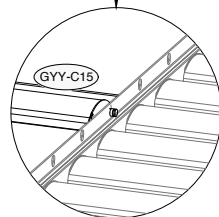
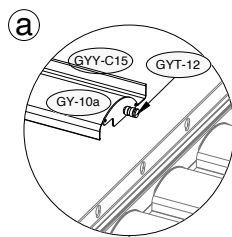
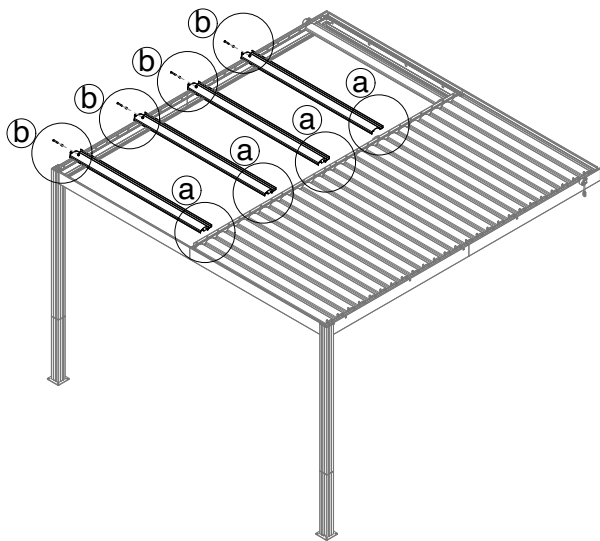

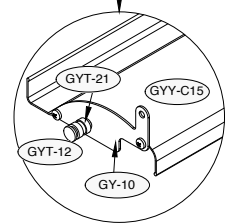
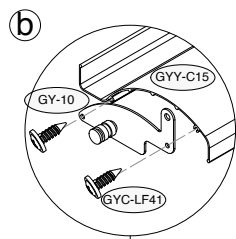
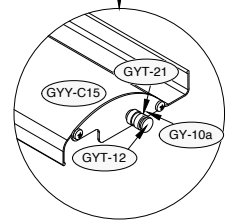
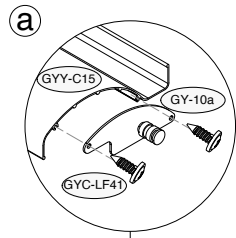
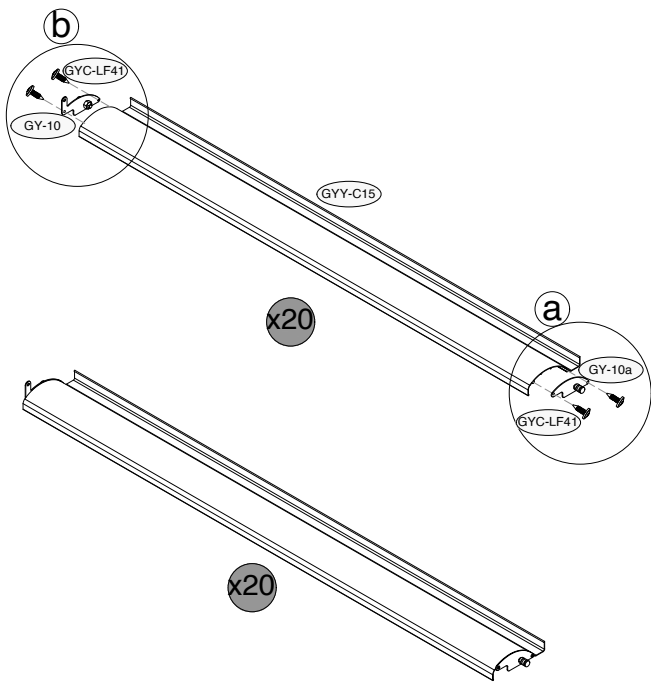

34			
	GYT-12c x4	GYT-21 x4	GYC-LF40 x4

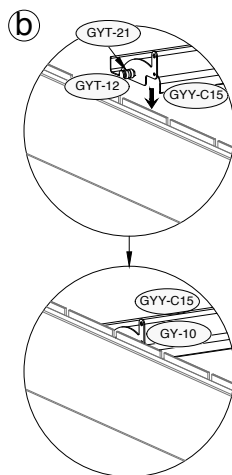
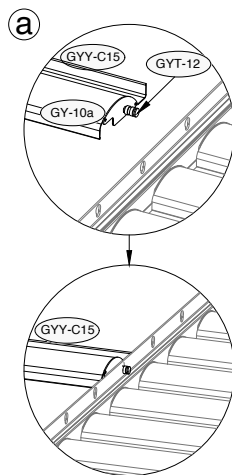
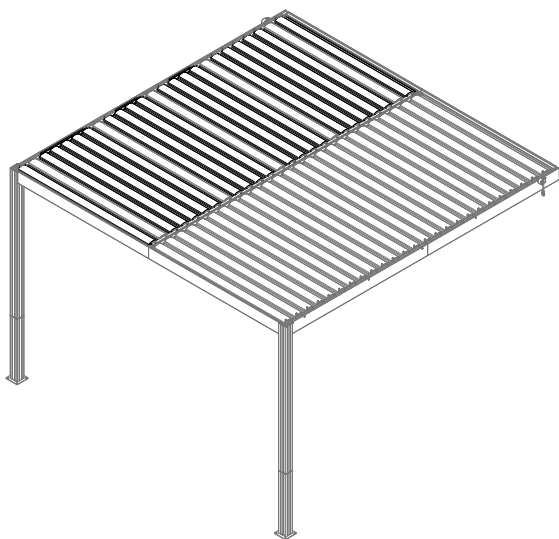
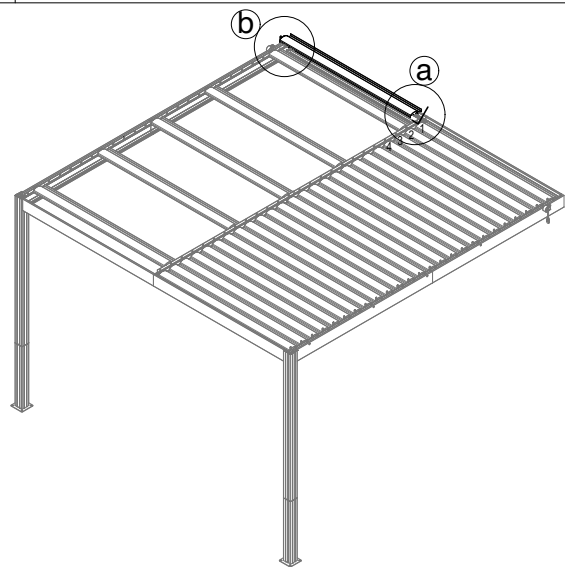

35	 GYY-C15 x20	 GYC-LF41 x80	
----	--	---	--





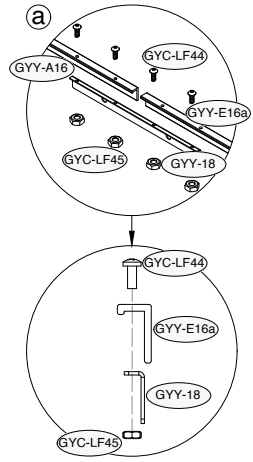
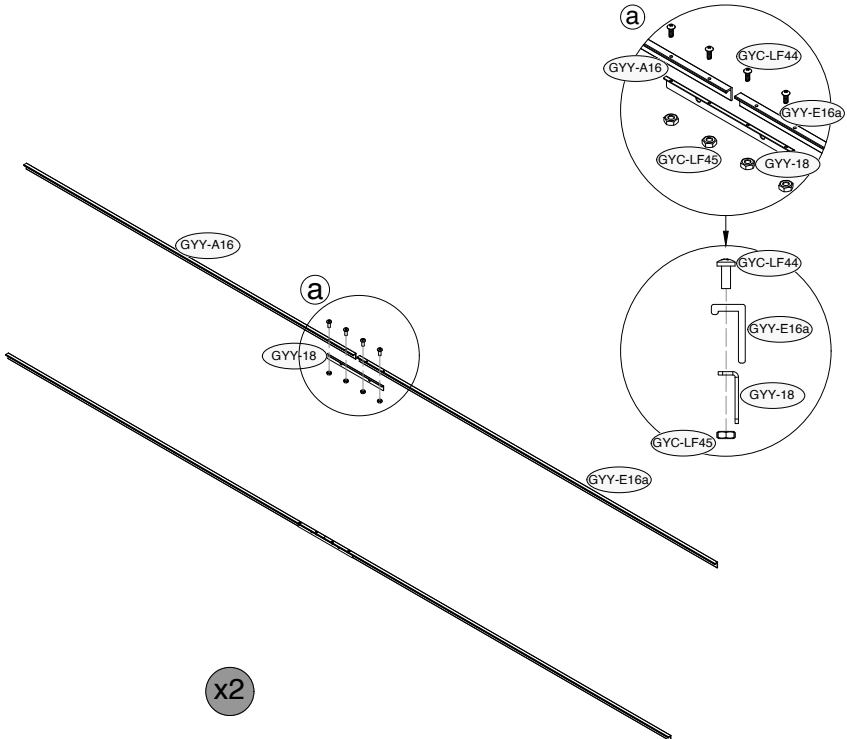

37						
	GY-Y-A16 x2	GY-Y-E16a x2	GY-Y-18 x2	GY-C-LF44 x8	GY-C-LF45 x8	







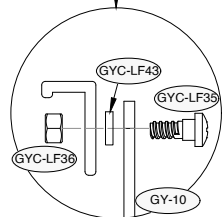
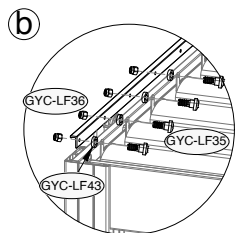
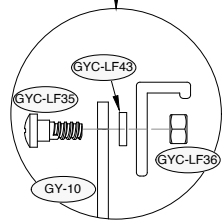
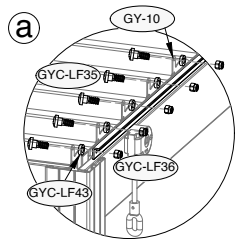
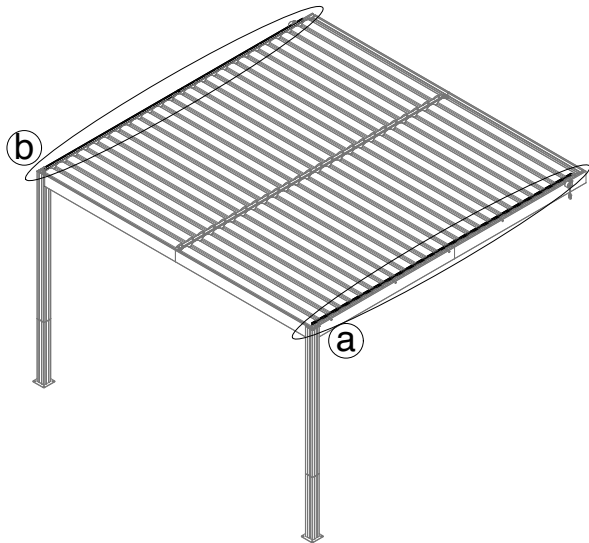
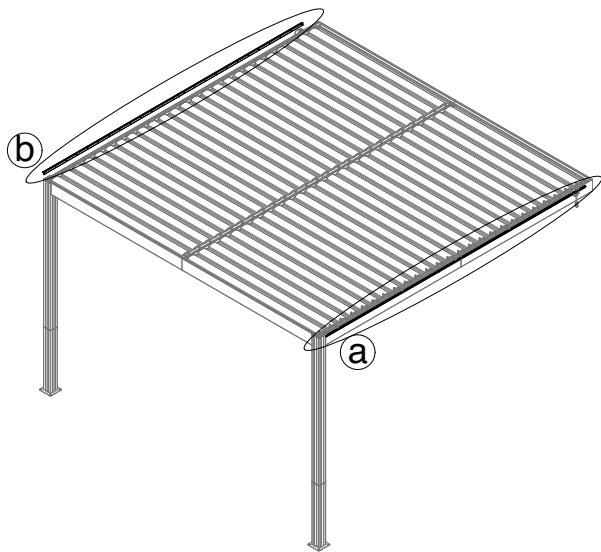

x2

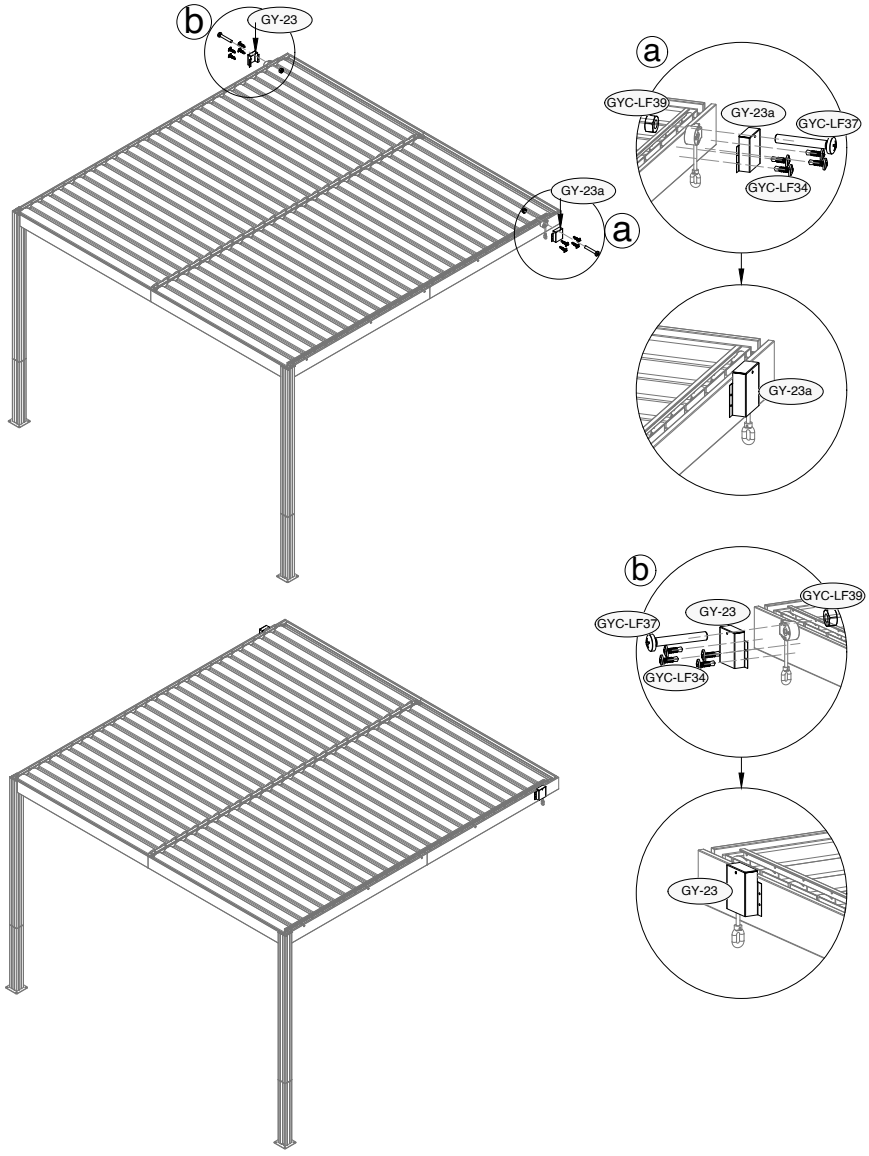
38	 GYC-LF35 x50	 GYC-LF43 x50	 GYC-LF36 x50	
----	---	---	---	--



39	 GY-23 x1	 GY-23a x1	 GYC-LF37 x2	 GYC-LF39 x2	 GYC-LF34 x8
-----------	--	---	---	---	---



40	 GY-14 x2	 GYC-14 x2	 GYC-LF33 x6	 GYC-LF34 x6	 GY-16a x2	
-----------	--	---	---	---	---	--

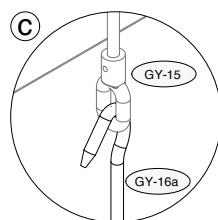
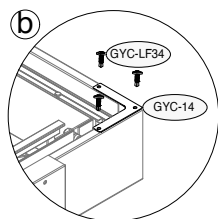
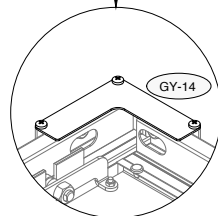
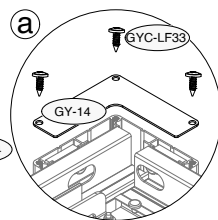
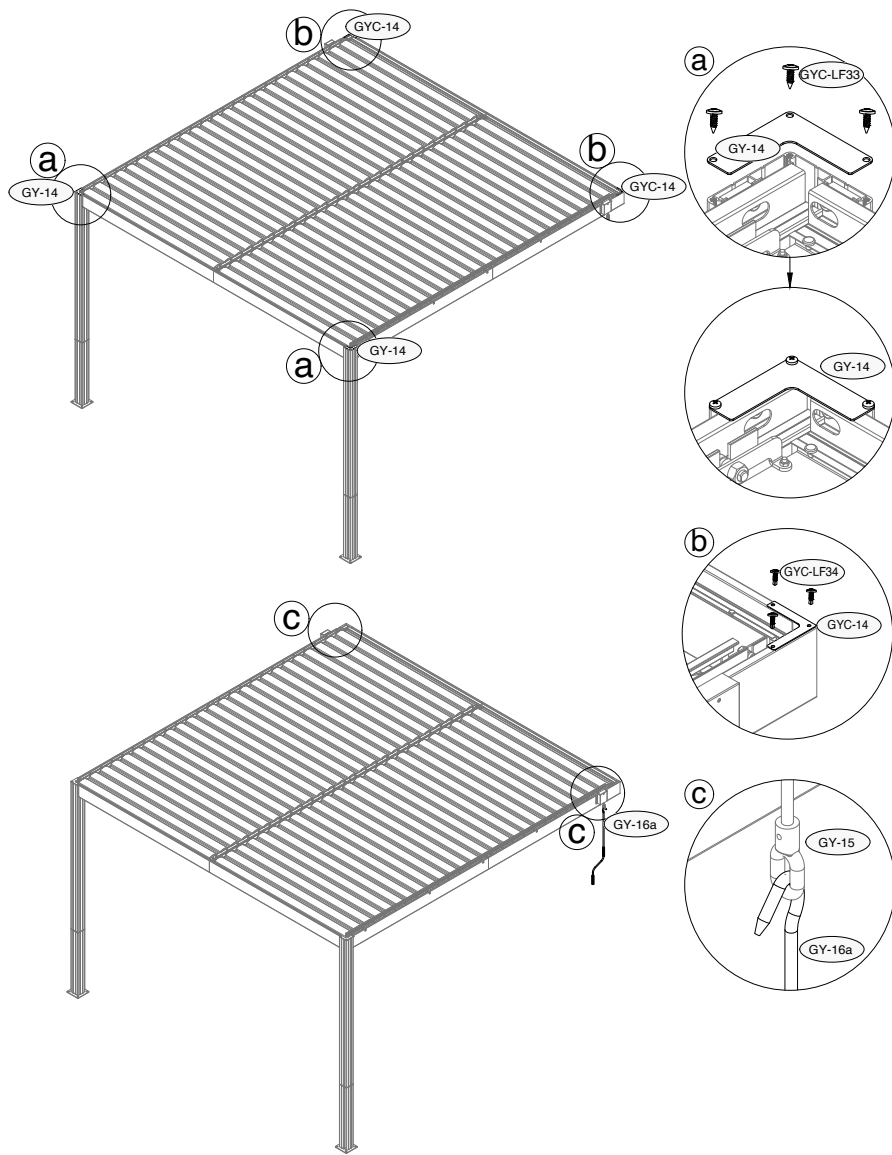

41



GYC-LF46 x100

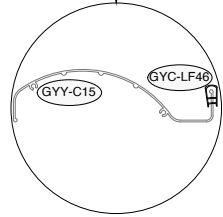
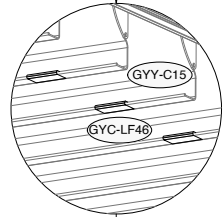
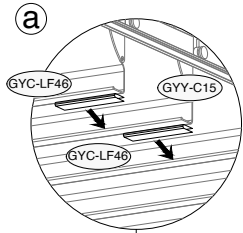
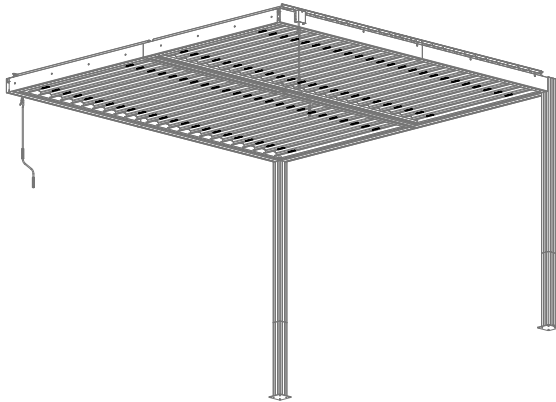
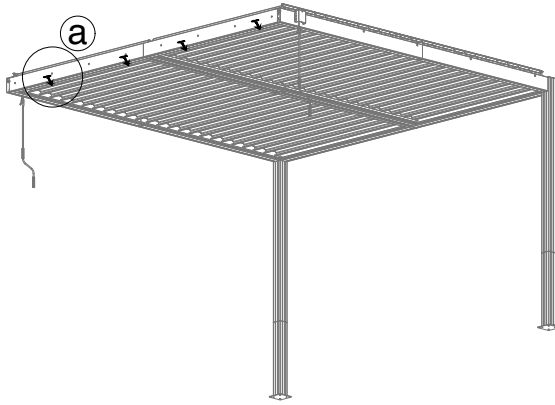

۲۷

